

Table of Contents

1. Introduction	1
2. Precaution	1
3. Product Introduction	
3-1 Specifications & Features.....	1
3-2 Front Panel	
3-2-1 Display	2
3-2-2 Keyboard.....	3
3-3 Rear Panel.....	4
3-4 Power Supply.....	5
4. Installation	
4-1 Load Cell Connection.....	5
4-2 Assembly Description of Upright Pole.....	5
5. Setting Mode	
5-1 Maximum Weighing Capacity Setting.....	7
5-2 Resolution Setting.....	7
5-3 Function Setting	8
6. Calibration Mode	
6-1 Linear calibration.....	10
6-2 Single point calibration.....	10
7. Operation	
7-1 Basic Weighing	
7-1-1 Weighing.....	11
7-1-2 Tare & Preset Tare.....	11
7-1-3 Unit Switch Operation	12
7-2 Basic Counting	
7-2-1 Upper & Lower Quantity Limit Checking	12
7-2-2 Entering a Known Unit Weight	12
7-2-3 Sample Counting & ACAI.....	13
7-2-4 Accumulation, Accumulation Display and Accumulation Clear.....	13
8. Serial Interface	
8-1 RS-232 Connector.....	14
8-2 Single Option.....	15
8-3 RS-232 Output Format.....	15
9. Troubleshooting and Error Message	16

1. Introduction

Thank you for deciding to purchase a JWI-700C Counting indicator from Jadever. This goods has the excellent performance and splendid properties under severe quality management .It is recommended to read this manual in full before using it for good function application.

2. Precautions

- ⊙ Place the indicator on a flat and stable surface .
- ⊙ Verify that the input voltage and the plug type matches the local AC power supply . See 3-4 power supply.
- ⊙ Keep the indicator away from EMI noise , strong wind and vibration ,which might cause incorrect reading.
- ⊙ Avoid sudden temperature changes (suitable operating temperature is between-5℃~40℃.)
- ⊙ Disconnect the power supply when cleaning the indicator .
- ⊙ Do not immerse the indicator in water or other liquids .

3. Product Introduction

3-1 Specifications & Features

Specifications

Model	JWI 700C
Input sensitivity	0.13uV/D
Input voltage range	-0.5mV to 16.5mV
Load cell excitation	DC 5V ,Up to 8 ×350 ohm load cells
System linearity	0.003% of full scale
Input impedance	10M ohm or more
AD conversion mode	Δ - Σ
A/D internal resolution	700,000 count
AD conversion speed	8 times/second
External display resolution.	15,000 count
Displays	LCD (6 Digits , 5 Digits, 6 Digits)
Power supply	AC 110V/220V (AC \pm 10%) or Rechargeable battery (6V/4A)

Features

- LCD display 6/5/6, LED backlight
- Kg and Lb switchable
- Up to 1/30000 resolution
- Adjustable capacities, resolutions and parameters
- Adjustable stand for bench scale
- Enclosed with PVC dustproof cover
- Able to adjust filter range and zero band
- Low battery and charging status indicator
- Automatic average weighing unit function
- Single point and linear calibration available
- HI/OK/LO indicator, HI/OK/LO alarm function
- Full range tare, pre-tare, auto-zero tracking
- Rechargeable battery or AC power
- Automatic counting accuracy improvement (ACAI)
- Accumulation of weight and quantity (max 99 pieces)
- Auto power off selection, save battery life
- Suitable for a wide range of bases and load cells

3-2 Front Panel

3-2-1 Display

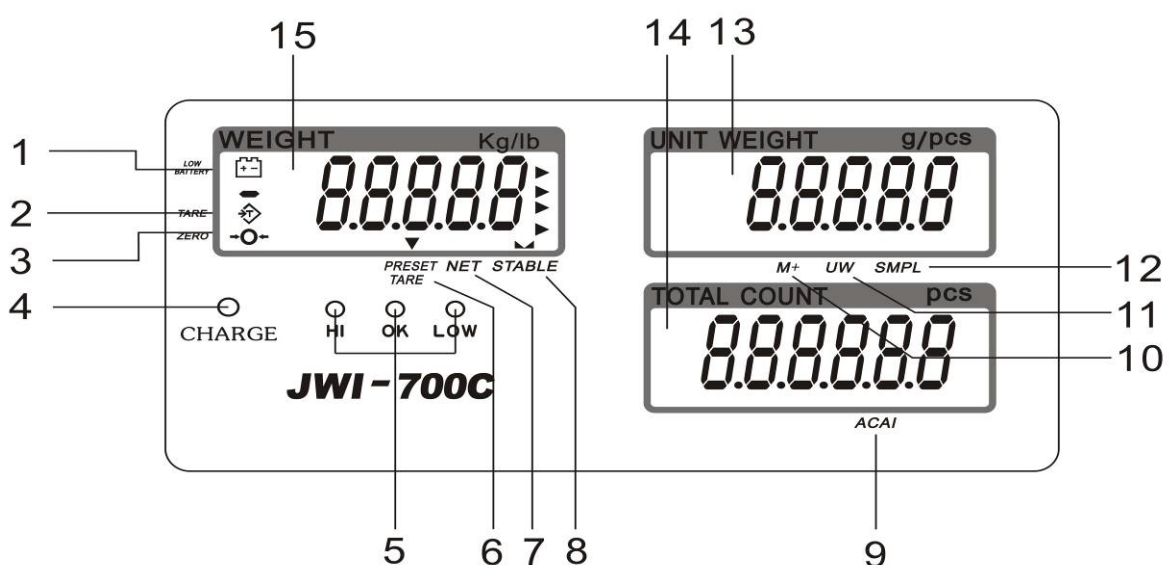

1)  Low battery indication

2)  Tare or Preset Tare indication

- 3)  Center of Zero Indication, The zeroing range is $\pm 2\%$ of weighing capacity.
- 4) **Charge Lamp**
- 5) **HI Lamp** (ON) –Indicating parameter item U_n is selected when setting buzz sounds. (See 5. Function Setting, setting buzz sounds)
- OK Lamp** (ON) -- Indicating parameter item i_n or n_n is selected when setting buzz sounds.
- LOW Lamp** (ON)--Indicating parameter item L_n is selected when setting buzz sounds.
- 6) **“PRESET TARE”** Symbol “▼” points at **“PRESET TARE”** when Tare value entered via numeric keys.
- 7) **“NET”** Net weight--Gross weight minus Tare. Symbol “▼” points at **“NET”** when TARE or PRESET TARE action is done.
- 8) **“STABLE”** Stable indication, Symbol “▲▲” appears at the top of **“STABLE”** when scale is in stable condition.
- 9) **“ACAI”** Symbol “▼” points at **“ACAI”** when Automatic counting accuracy improvement is functioning.
- 10) **“M+”** Symbol “▼” points at **“M+”** when scale is in accumulation mode.
- 11) **“UW”** Under entering a known unit weight mode, Symbol “▼” points at **“UW”** when entered unit weight is lower than 4/5 of scale division. Unit weight is too small for ensuring accurate quantity calculations.
- 12) **“SMPL”** Under the sample counting mode, Symbol “▼” points at **“SMPL”** when calculated unit weight is lower than 4/5 of scale division or the quantity of sample is less than 10 pieces.
- 13) **“UNIT WEIGHT”** Unit Weight Window --Displays the average unit weight value, or number of weighments.
- 14) **“TOTAL COUNT”** Total count window –Displays the calculated number of pieces on the weighing pan, or accumulated piece count value.
- 15) **“WEIGHT”** Weight Window--Displays weight of object on weighing pan, or accumulated weight value.

3-2-2 Keyboard

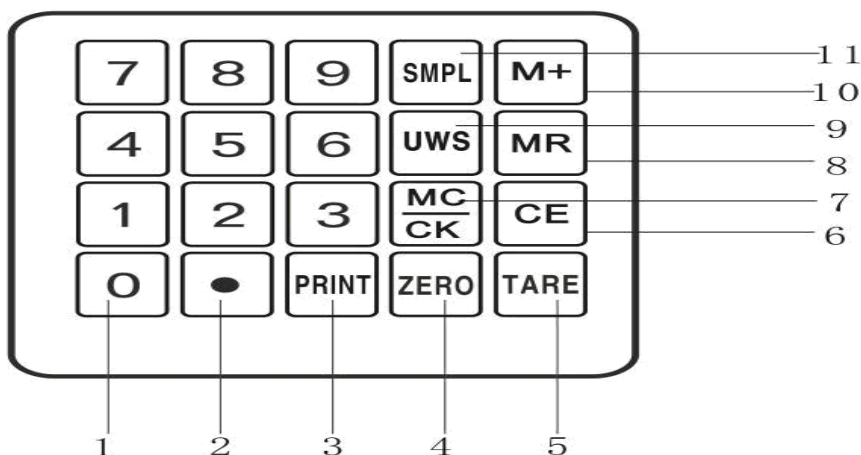

- 1) **0 ~9** numeric keys Enters specific values for tare; unit weight and other data entries.

- 2) **•** key Decimal point ; toggles between upper limit and lower limit setting when HI-LO-OK function is enabled .(see 7-2-1)
- 3) **PRINT** key Outputs data when Prt.Pr (print stably) is selected as the print mode.
- 4) **ZERO** key Zeros the display (within 2% of max.capacity) or cancels Tare action.
- 5) **TARE** key Inputs the weight of the object on the weighing pan as a Tare value ; Inputs the indicated value entered via the numeric keys as a pre-set Tare value ; cancel tare action.
- 6) **CE** key Clears the indicated input values.
- 7) **MC/CK** key Short press deletes accumulation records; long press to initial Upper & Lower Quantity Limit setting.
- 8) **MR** key Recalls and displays the total Accumulation data (weight, total count and number of weightments) and the first 10 records in details.
- 9) **UWS** key Inputs the indicated unit weight value entered via numeric keys
- 10) **M+** key Adds the indicated weight or piece count value into Accumulation memory.
- 11) **SMPL** key Short press enters the sampling mode.

3-3 Rear Panel

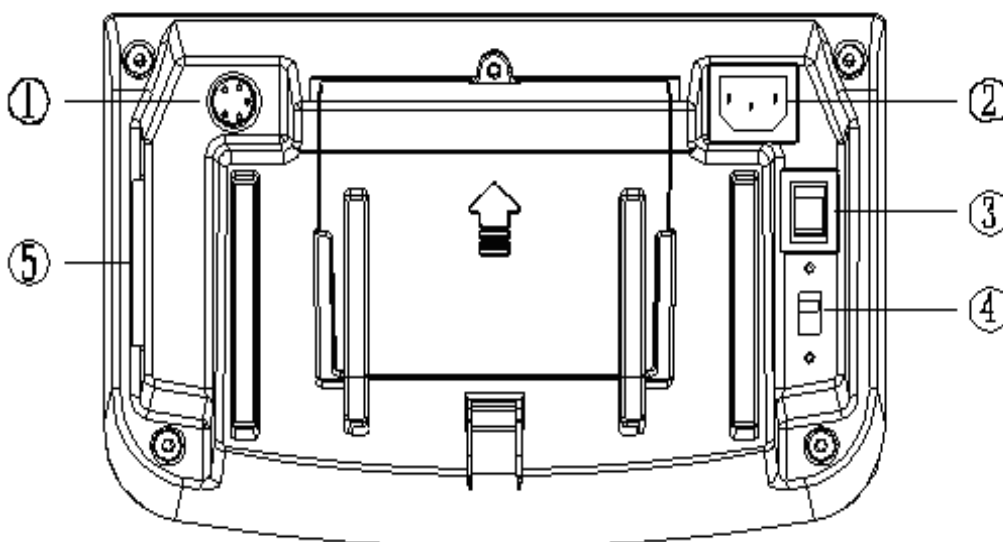

- 1) Port for connecting load cell.
- 2) power socket
- 3) power ON/OFF switch
- 4) Two-stage switch(110V or 220V)
- 5) RS-232 port: Serial interface port (computer, printer and Light Tower)

3-4 Power supply

Please verify the local AC power source and switch the two-stage switch to the proper place before plugging into the power outlet.

Alternative power supply

- 1) AC 110V/220V (AC±10%)
- 2) (6V/4A) Internal Rechargeable Battery

Power Consumption

About 300mW, 80hrs (without backlight)
 About 380 mW, 65hrs (with backlight)

Low battery warning

When “” appears in the upper left corner of the weight window, the battery power requires recharging. The charge lamp turns green from red when the recharging is completed (which takes about 8 hours). Disconnect the scale from power supply when it is fully charged. Note: Battery is to replaced only by an authorized service dealer .Risk of explosion can occur if replaced with the wrong type or connected improperly.

4. Installation

4-1 Load Cell Connection

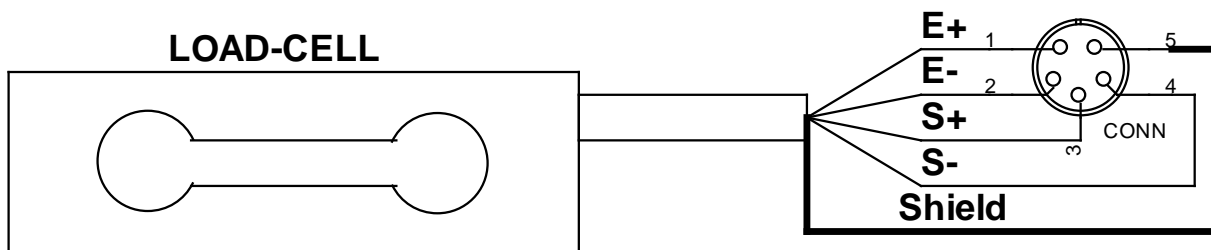

	PIN	SIGNAL
LOAD CELL	1	E+
	2	E-
CONNECTION	3	S+
	4	S-
	5	SHIELD

4-2 Assembly Description of Upright Pole

- (1) Rod seat
- (2) Upright pole
- (3) Bracket
- (4) Indicator
- (5) Screw (for fixing the upright pole)
- (6) Screw (for fixing the Bracket)
- (7) Knob pole
- (8) Bracket slot
- (9) Load cell wire

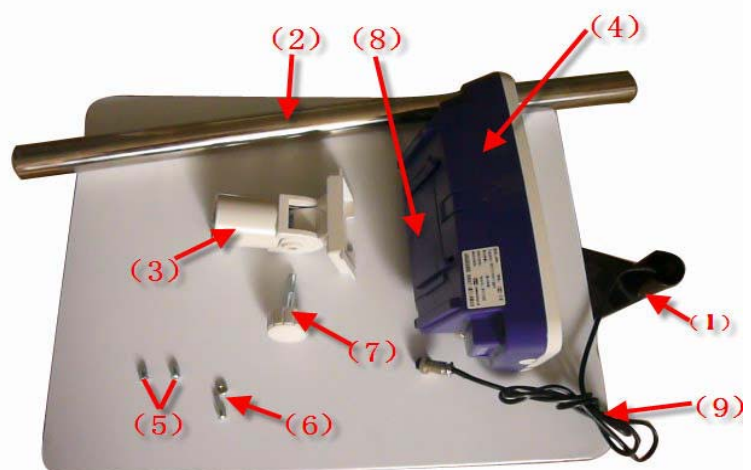

Step 1: Thread the wire of the Load Cell (9) on the rod seat (1) through the upright pole (2), insert the upright pole into the rod seat and then lock it with two screws (5).



Step 2: After threading the Load Cell wire through the bracket (3), attach the bracket to the upright pole and then lock it with the screw (6).



Note: if the load cell connector is too big to thread through the bracket, separate the bracket by removing the Knob pole (7), see the following pictures.

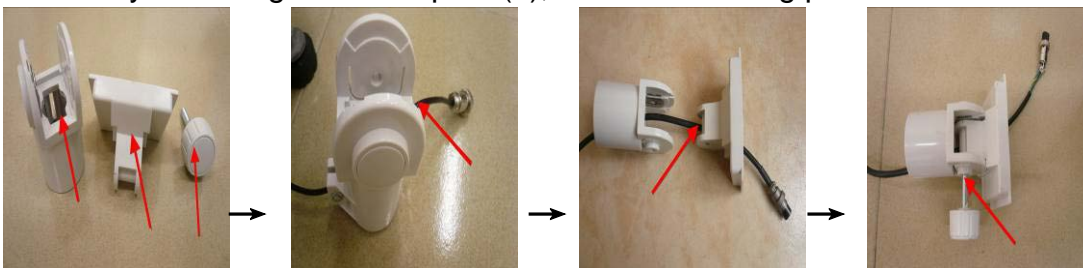

Step 3: Install the Indicator (4) on the bracket, with the bracket aligning with the bracket slot (8) of the indicator.



Step 4: After connecting load cell connector to load cell port, the installation is completed.

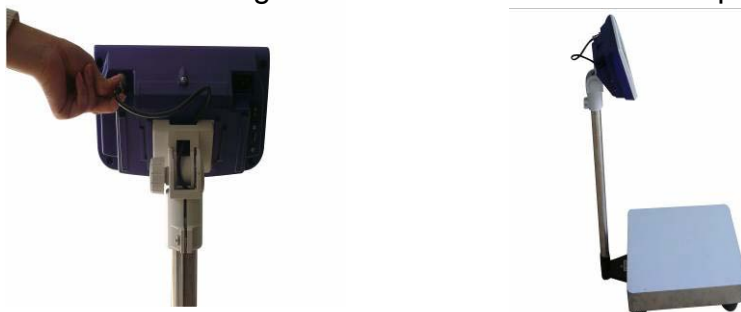

Note: Use the knob pole (7) to adjust the inclination angle of indicator and the screw (6) to adjust direction of the indicator. After adjusting the indicator to an optimal position and lock the screw.

5. Setting Mode

5-1 Maximum Weighing Capacity Setting

- 1) Turn on the power while pressing key **ZERO**.
- 2) Press key **•** to cycle through weight capacity options. Available settings are 15,30,60,75,150,300,600,750,1500,3000,6000 and7500 (kg).Here we choose (75kg).
- 3) Press key **SMPL** to save and return to the Setting Menu.
- 4) Press down numeric key **1** to check the current weighing capacity and division.
- 5) Press key **ZERO** to go back to the weighing mode.

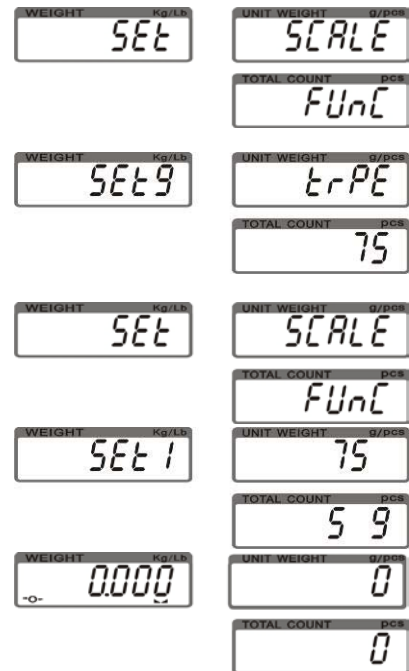

5-2 Resolution Setting

- 1) Turn on the power while pressing key **SMPL**.
- 2) Key in 1123 with the numeric keys.
- 3) Enter the resolution selection mode by pressing key **SMPL**. Numeric Key **1** is to circle through resolutions options. Available setting are 1(1/6000 or 1/7500),2 (1/15000) and3(1/30000).
- 4) Press to key **SMPL** save and return to the setting menu.
- 5) Press key **ZERO** to return to weighing mode.

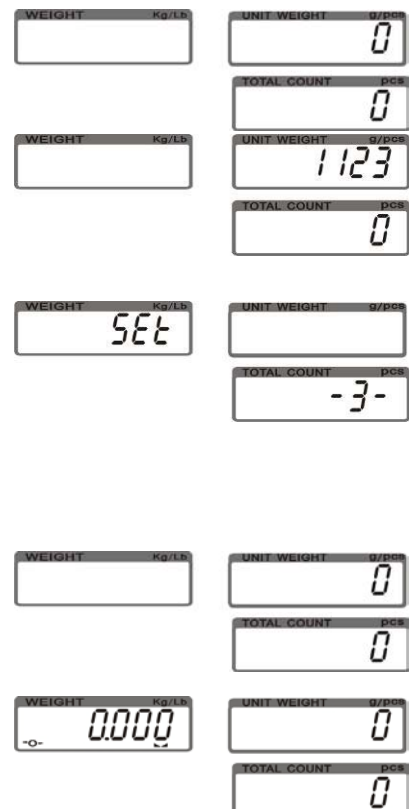

Note: Division changes with the changing of resolution. when weight unit Lb is selected, it won't be possible to shift to resolution 1.

5-3 Function Setting

1) Turn on the power while pressing key **ZERO**.

Note: The following Steps (2) ~ (11) do not require to operate in order.



2) Press numeric key **0** to shift backlight modes.

Options are On, OFF and OnOFF.

OnOFF = Auto-on with items greater than 9d placed on the pan.

OFF = No backlight

On = Backlight



3) Press numeric key **2** to set the level in which the stable indication turns on (filtering). The lower the setting, the faster stabilization time.

Options are 1 and 2(level).



4) Press numeric key **3** to set the period of inactivity before the scale automatically turns off. Options are OFF(Non power-off) 、 5、 10、 30 and 60 (minutes).

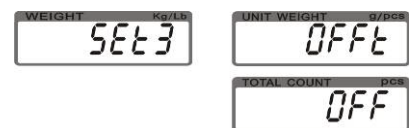

5) Press numeric key **4** to set the range in which the Zero indication turns on. Options are d0, d1, d2, d3, d4 and d5. (d= scale division)



6) Press numeric key **5** to select serial transmission rates. Options are 9600, 4800 and 2400 .

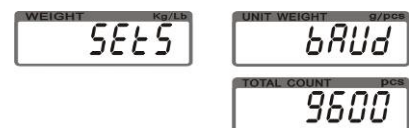

7) Press numeric key **7** to set buzz sounds. Options are Un , In , no , Lo and nbEEP.



Un = There will be a warning sound when the quantity of the articles exceeds the upper limit.

In = There will be a warning sound when the quantity of the articles is between the upper and lower limit (including the upper and lower limits).

no = There will be a warning sound when the material quantity exceeds the upper and lower limits, and the weight of the material is more than 20 divisions.

LQ = There will be a warning sound when the material quantity is less than the lower limit, and the weight of the material is more than 20 divisions.

$noEEP$ = No sound alarm.

8) Press numeric key **8** to set whether to save the upper & lower limit of quantity checking.



$11.0FF$ = Previously set quantity checking values are not retained when the unit is turned on.

$11.00n$ = Previously set quantity checking values are retained when the unit is turned on.

9) Press numeric key **9** to set print modes .Options are Prt.Pr, Prt.Co and Prt.St. If Prt.Co is chosen as the print mode, PC will be automatically selected as the external devices.



$Prt.Pr$ = manual print

$Prt.Co$ = continuous print

$Prt.St$ = Stable printing (the weight of the weighted articles should be more than 9 divisions. Weighted articles should be removed and the scale goes back to zero before print out the next record.)

10) Press key **MC/CK** to select external devices.



Options are PC , AX , TP , Godex ,SH ,

ET , TDP and ZEBRA.

11) Press Key **MR** to switch On or OFF RTC function.



12)When setting is completed, press key **ZERO** to save and return to weighing mode.

6. Calibration Mode

1) If good linearity of the load cell was not guaranteed, linear calibration is required. After the linear calibration is made, there is no need to make single point calibration.

2) If there is limit in weights, single point calibration is needed .it would be more accurate to calibrate the scale with 1/3 or more of the full load.

3) Here we take 75kg weighing capacity as an example.

6-1 Linear calibration

- 1) Turn on the power while pressing key **TARE** to initiate linear calibration.
- 2) Again press key **TARE** to enter zero calibration mode, with “**on 0**” flashing on the weight window.
- 3) Wait till “**on 1**” appears put weights of 1/3 of full load on the weighing pan and press down key **TARE**. (E.g. for 75kg weighing capacity, 1/3 of full load is 25kg)
- 4) Wait till “**on 2**” appears, then put weights of 2/3 of full load (50kg) on and press down key **TARE**.
- 5) Wait till “**on 3**” appears, then put weights of full load(75kg) on and press key **TARE**.
- 6) The calibration Procedure is completed with a symbol of “**PASS**” flashing, then take away the weights.
- 7) Press key **TARE** to return to weighing mode.

WEIGHT Kg/Lb	UNIT WEIGHT g/PCS
SEt	0

TOTAL COUNT PCS
0

WEIGHT Kg/Lb	UNIT WEIGHT g/PCS
on 0	

UNIT WEIGHT g/PCS

TOTAL COUNT PCS

WEIGHT Kg/Lb	UNIT WEIGHT g/PCS
on 1	

UNIT WEIGHT g/PCS

TOTAL COUNT PCS

WEIGHT Kg/Lb	UNIT WEIGHT g/PCS
on 2	

UNIT WEIGHT g/PCS

TOTAL COUNT PCS

WEIGHT Kg/Lb	UNIT WEIGHT g/PCS
on 3	

UNIT WEIGHT g/PCS

TOTAL COUNT PCS

WEIGHT Kg/Lb	UNIT WEIGHT g/PCS
PASS	

UNIT WEIGHT g/PCS

TOTAL COUNT PCS

6-2 Single point calibration

- 1) Turn on the power while pressing key **SMPL** to initiate single point calibration.
- 2) Input 11 with numeric keys
- 3) Again press key **SMPL** to enter the zero point calibration mode, with “**0**” flashing.

WEIGHT Kg/Lb	UNIT WEIGHT g/PCS
	0

UNIT WEIGHT g/PCS
0

TOTAL COUNT PCS
0

WEIGHT Kg/Lb	UNIT WEIGHT g/PCS
	11

UNIT WEIGHT g/PCS
11

TOTAL COUNT PCS
0

WEIGHT Kg/Lb	UNIT WEIGHT g/PCS
CAL	0

UNIT WEIGHT g/PCS
0

TOTAL COUNT PCS
-H9-

4) Wait till "0" is stable, key in the calibration value 25(1/3 full load) and put the corresponding weights



On, then press key **UWS**. "25" is flashing.

5) The calibration procedure is completed with a "PASS" flashing on the weight screen. Now, remove all the weights.



6) Press key **SMPL** to save, and then press key **ZERO** to return to normal weighing mode.

7. Operation

7-1 Basic Weighing

7-1-1 Weighing

Place item to be weighed on the scale. The Weight window shown is 2.000kg, Gross Weight.





7-1-2 Tare & Preset Tare

Tare

When weighing a sample that must be held in a container, taring stores the container weight into memory.

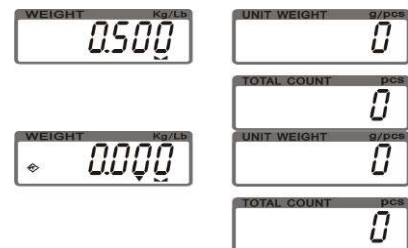
1) Under the weighing mode, place the container on the scale, weight window shown is 0.500kg. Press the Key **TARE** to complete tare action.



The  symbol appears and with symbol "▼" pointing at "NET".

2) To clear tare, with an empty pan, Press down the key **TARE** or key **ZERO**.

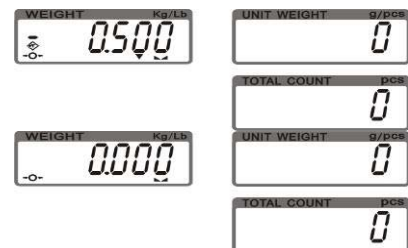

Preset Tare

1) Under the unload condition, Enter tare value using the numeric keys together with key **•**, then press key **TARE**. The weight window displays the tare value.



2) Put the load on the container, the scale will automatically deduct the value of the container from the total value.

Note: during the process of Tare or Preset Tare, if the load and container are not removed, press zero to check the gross weight.

7-1-3 Unit Switch Operation

1) Press key **SMPL** while powering on the scale.



2) Key in 1132 via numeric keys.



3) Again press key **SMPL** to enter unit selection



mode. Numeric key **1** is to toggle between kg and Lb units.

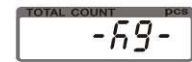

4) Press key **SMPL** to save, and then press key **ZERO** to return to the weighing mode.

7-2 Basic Counting

7-2-1 Upper & Lower Quantity Limit Checking

1) Under the weighing mode, press and hold key **MC/CK** to initial upper/lower limits



setting. (“**[H]**” is blinking.)

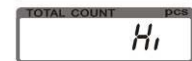

2) Use numeric keys to set the upper/lower Limits. Key **•** is to save upper limit value and advance to the lower limit setting.

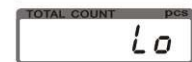
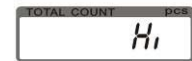

3) When setting is completed, again press key **MC/CK** to return to weighing and checking mode.

4) To cancel checking action , long press key **MC/CK**, then press key “ **•** ” twice .Checking action is cancelled, with “**[L]**”displays momentarily before the screen go back to zero mode.

7-2-2 Entering a Known Unit Weight

1) Under the weighing mode, use the numeric keys together with key “ **•** ” to input unit weight



value, and then press **UWS**.

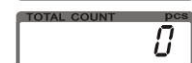

2) Put the article on the weighing pan , the scale starts counting.

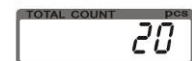

Note: Symbol “ ” points at “**UW**” when entered unit weight is lower than 4/5 of scale division.

7-2-3 Sample Counting & ACAI

Sample Counting

1) Place samples onto the weighing pan
(Or into a tared container) and input the

quantity with numeric keys, then press key **SMPL**.

The unit weight is calculated, with Symbol “▼” Pointing at “ACAI”.

Note:

- The larger the sample size, the more accurate unit weight.
- Symbol “ ▼ ” points at “SMPL” when calculated unit weight is lower than 4/5 of scale division or the quantity of sample is less than 10 pieces.

2) Remove the samples and put the load on, the scale begins to count.

3) Press key **CE** to return to the weighing mode.



ACAI

Automatic Counting Accuracy Improvement (ACAI) results in a more accurate count by increasing the reference weight without the need to count additional parts. A higher reference weight is important when there is a risk of inconsistent piece weights or if the reference weight is close to the minimum. ACAI uses an initial averaging unit weight to count additional pieces that are placed on the scale .after a few seconds, the scale gives a beep as the new higher reference weight is used to recalculate the averaging unit weight. The process can be repeated as long as the additional weight is less than the previous reference weight . Once this limit is exceeded ACAI is turned off.

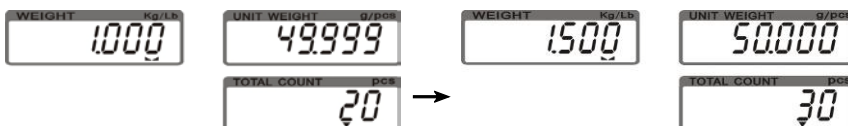

7-2-4 Accumulation, Accumulation Display and Accumulation clear

1) Enter the indicated unit weight, press key **UWS**

and put first piece of load on the weighing pan
(or into a tared container). (Refer to 7-2-2)

2) Press key **M+**, the first accumulation event

is displayed momentarily before Symbol “▼”
pointing at “**M+**”. The display reverts to normal
weighing mode in a second .Remove the first piece
of load.

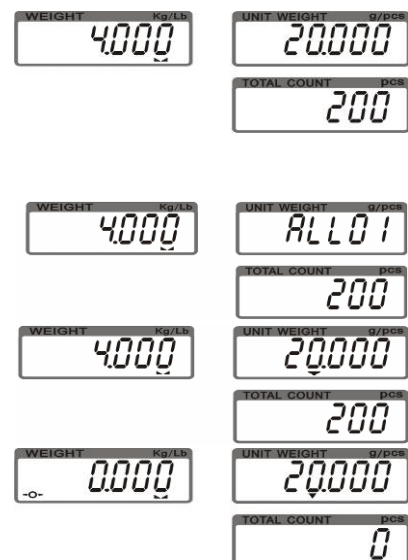

3) Put the second piece of load on, then press key **M+** to add the second accumulation event into memory. Repeat step 2-3 till accumulation actions are finished.

Note: Maximum is 99 pieces.

Accumulation display

Press key **MR** to displays the total accumulation data (weight, count and number of weighments) and the first 10 accumulation events in detail.

Accumulation clear

To clear the total accumulation data or the first 10 accumulation events, Press key **MC/CK** while the data is displayed. Symbol “▼” disappears when the total accumulation data is deleted.

8. Serial Interface

If external interface is needed, please select the proper two-in-one board first, which integrates RTC (time display), RS-232 and relay (weight checking) functional module onto one circuit board. Only when this board is adopted, the three functions can be enabled.

8-1 RS-232 connector

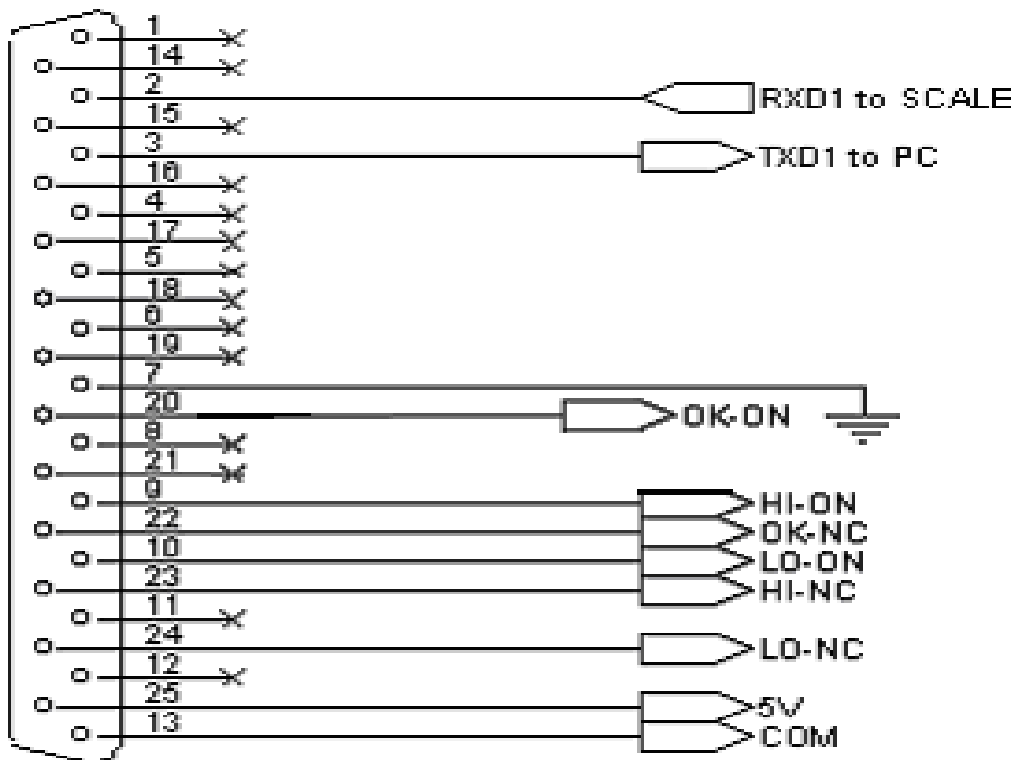

RS232/RELAY

8-2 Single Option

- 1) RS232+RTC+Relay+ TDP / SH-24 (TP) / ZEBRA / GODEX printer
- 2) RS232+RTC+Relay+ LED Light Tower (Applicable to the quality control of the factory product quantity or weight and that of the total production line.)
- 3) RS232+RTC+Relay+Computer

8-4 RS-232 Output Format

Baud Rate : 2400、4800、9600

Data Bit : 8

Parity : N (None)

Stop Bit : 1

Code : ASCII

Bit Format :

	LSB							MSB		
	0	1	2	3	4	5	6	7	8	
Start									Parity	Stop

Data Format :

Kg

G/N	.	W	.	:	+/-							k	g	CR	LF	
weight																
U	.	W	.	:						g	/	p	c	s	CR	LF
Unit weight																
T	o	t	a	l	:							p	c	s	CR	LF
pcs																

Example:

G.W. : + 2.2352 kg

U.W. : + 0.5352 g/pcs

Total : 4176 pcs

lb

G/N	.	W	.	:	+/-							l	b	CR	LF		
weight																	
U	.	W	.	:						l	b	/	p	c	s	CR	LF
Unit weight																	
T	o	t	a	l	:							p	c	s	CR	LF	
pcs																	

Example:







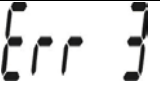

G.W. : + 2.2352 lb

U.W. : + 0.5352 lb/pcs

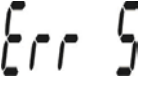
Total : 4pcs

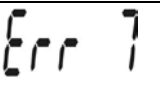
G = GROSS N = NET

9. Troubleshooting and Error message

Error message	Problems	Solutions
	Initial zero point exceeds $\pm 30\%$ (take 30% as reference basis).	<ol style="list-style-type: none"> To check whether there are other alien articles on the scale pan, remove those articles. LOAD CELL failure, which requires to be changed or to contact our Service.
	Higher or lower than A/D resolution range.	<ol style="list-style-type: none"> Check whether it is A/D failure, if yes, please replace AD. LOAD CELL failure, replacement is required or contact our Service.
	EEPROM Check sum failure	Re-sold EEPROM or contact our Service.
	The weighed articles are overload .	Do not load the item exceeds the maximum tolerance.
	The calibration value exceeds the full load capacity while processing single point Calibration.	Adjust the calibration value.
	The accumulated number of weighments, total count or weight exceeds display range.	No more accumulations.
 (total count window)	Under unit weight entering or sampling mode, the quantity of weighed articles exceeds display range.	-----
 (unit weight window)	The calculate unit weight exceeds the display range during sampling.	-----
	Low battery	Recharge the battery, the indicator can be used while it is charging.

