

Standard Configurations

Power			
Model	Capacity/Readability	Versions	Product Size
ICS226-QA3F	3 kg / 1 g	Front	375 x 331 x 86 mm
ICS226-QA6F	6 kg / 2 g	Front	
ICS226-QA15F	15 kg / 5 g	Front	
ICS226-QA3R	3 kg / 1 g	Rear	359 x 331 x 158 mm
ICS226-QA6R	6 kg / 2 g	Rear	
ICS226-QA15R	15 kg / 5 g	Rear	
Internal Rechargeable Battery			
ICS226-QA3FCL	3 kg / 1 g	Front	375 x 331 x 86 mm
ICS226-QA6FCL	6 kg / 2 g	Front	
ICS226-QA15FCL	15 kg / 5 g	Front	
ICS226-QA3RCL	3 kg / 1 g	Rear	359 x 331 x 158 mm
ICS226-QA6RCL	6 kg / 2 g	Rear	
ICS226-QA15RCL	15 kg / 5 g	Rear	

Front mounting

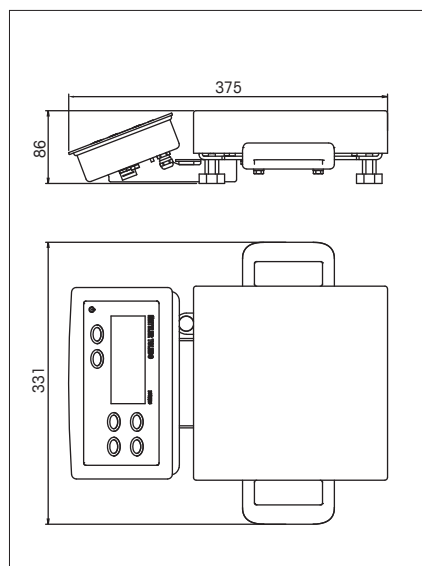

Rear mounting

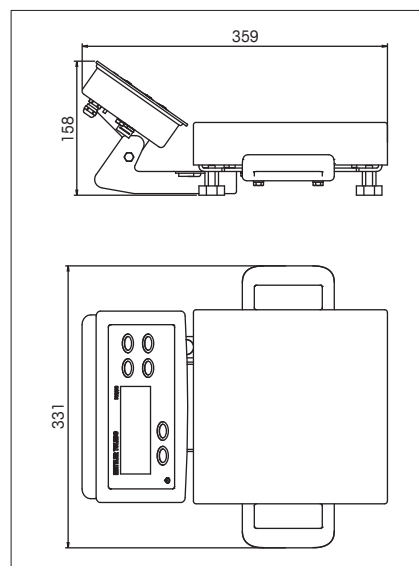

ICS226 Compact Scale



ICS226 Compact Scale

- Full stainless steel construction
- Water resistant according IP65/IP67
- Capacities from 3 to 15 kg
- Over/Under checkweighing
- Easy handling and operation
- Robust and reliable

www.mt.com

Visit for more information

Mobile, Ergonomic, Compact for Light Wash Down Applications

METTLER TOLEDO

Industry/Retail
 Add: 111 West Tai Hu Road, Xinbei District,
 Changzhou, Jiangsu
 Tel: 0519-86642040
 Fax: 0519-86641991
 E-mail: ad@mt.com

Laboratory/Process/Packaging Industry
 Add: 589 Gui Ping Road, Shanghai
 Tel: 021-64850435
 Fax: 021-64853351
 E-mail: ad@mt.com

30032409-R1 Printed in P. R. China 2011/12



METTLER TOLEDO

Highest Flexibility in Light Wet & Humid Environments

The ICS226 Compact Scale is an ideal portable scale solution for weighing and portioning in food production and packaging applications. This full stainless steel scale is IP65/IP67 protected and a good fit in any light wash down application with a need for ruggedness and durability.

This scale is designed for efficient out-of-the-box simple weighing applications and optimized for easy and fast checkweighing. Its large, intuitive and

fast LCD-display with an excellent visible checkweighing indicator speeds up production and helps to prevent manual operation errors.

The ICS226 Compact Scale is available in two basic versions: front or rear mounting, a together with its duplicated Zero/Tare keys grants for ergonomic handling and operation at any time.



Technical Specifications

Display	6 digit LCD, with white backlight Heights 30mm
Readability	3,000 d (factory setting) / 6,000 d / 7,500 d
Power Supply	100 ~ 240 VAC 6V Ni-MH rechargeable battery 3800mAh
Ingress Protection	IP65/IP67
Material	Scale: Stainless steel, AISI304 Load cell: Stainless steel potted
Applications/Features	Simple weighing, Checkweighing, Unit switch
Platform Size	228 x 228 mm



Good Readability

The ICS226 Compact Scale provides a large and excellent visible LCD-Display and an intuitive graphic checkweighing indicator for outstanding readability.



Unique, Ergonomic and Rugged Keypad Design

The high quality membrane keys and the duplicated Zero/Tare buttons grant a long life time and allow for user adapted handling of the terminal.

Highest Manufacturing Flexibility

Removable handles and the high quality Ni-MH rechargeable battery make the ICS226 a fully portable and mobile scale for flexible operation everywhere in the facility.



Stainless Steel Load Cell

The advanced and state of the art technology makes this load cell a perfect choice for light wash down applications.



Workplace Oriented

The two available basic scale set-ups – front and rear mounting – allow to optimal adjust the scale to given application requirements and workplace surroundings.