

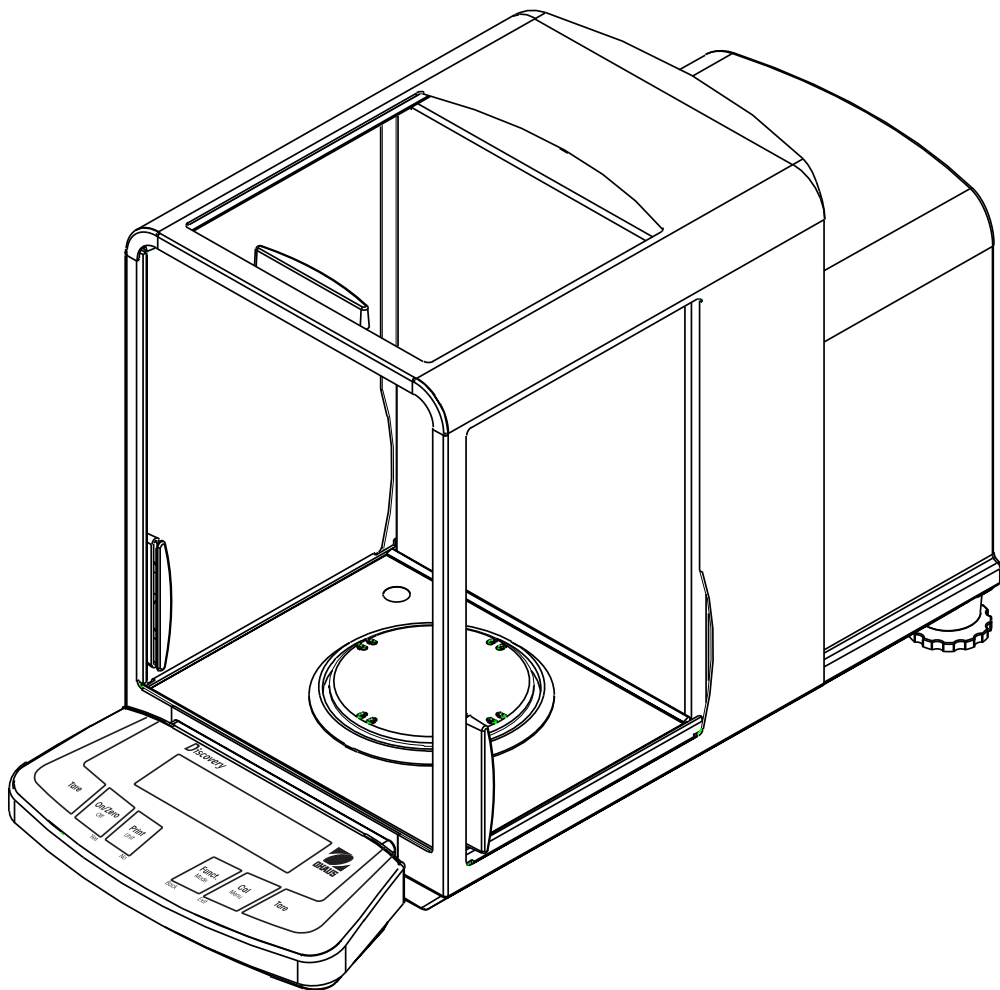



Ohaus Discovery Balances Instruction Manual



Ohaus Corporation, 19A Chapin Road, P.O. Box 2033 Pine Brook, New Jersey, 07058, USA

Declaration of Conformity We, Ohaus Corporation, declare under our sole responsibility that the balance models listed below marked with "CE"
- are in conformity with the directives and standards mentioned.

Instrument Type: Discovery Series

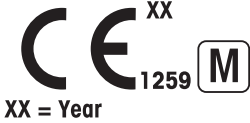
EC Marking:	EC Directive	Applicable Standards
	73/23/EEC Low Voltage	EN61010-1: 2001
	89/336/EEC Electromagnetic compatibility	EN61326:1997+A1:A2:01+A3:03 (class B) EN61326:1997+A1:A2:01+A3:03 (minimal requirements)
<p><i>For non-automatic weighing instruments used in an Article 1, 2.(a) application, additional metrological marking according to Annex IV of Council directive 90/384/EEC must be attached to the instrument</i></p>		
 <p>XX = Year</p>	90/384/EEC Non-Automatic Weighing Instruments	EN45501:1992 *

* Applies only to certified non-automatic weighing instruments.
Date: April 1, 2006



Ted Xia
President
Ohaus Corporation
Pine Brook, NJ USA



Urs Müller
General Manager
Ohaus Europe
Greifensee, Switzerland

Important notice for verified weighing instruments



Weighing Instruments verified at the place of manufacture bear one of the preceding mark on the packing label and the green 'M' (metrology) sticker on the descriptive plate. They may be put into service immediately.



Weighing Instruments to be verified in two stages have no green 'M' (metrology) on the descriptive plate and bear one of the preceding identification mark on the packing label. The second stage of the initial verification must be carried out by the approved service organization of the authorized representative within the EC or by the national weight & measures (W+M) authorities.

The first stage of the initial verification has been carried out at the manufacturers work. It comprises all tests according to the adopted European standard EN 45501:1992, paragraph 8.2.2.

If national regulations limit the validity period of the verification, the user of the weighing instrument must strictly observe the re-verification period and inform the respective W+M authorities.

Disposal



In conformance with the European Directive 2002/96/ EC on Waste Electrical and Electronic Equipment (WEEE) this device may not be disposed of in domestic waste. This also applies to countries outside the EU, per their specific requirements.



Please dispose of this product in accordance with local regulations at the collecting point specified for electrical and electronic equipment.

If you have any questions, please contact the responsible authority or the distributor from which you purchased this device.

Should this device be passed on to other parties (for private or professional use), the content of this regulation must also be related.

Thank you for your contribution to environmental protection.

Compliance to the following standards is indicated by the corresponding marking on the product.

Mark	Standard
 N13123	AS/NZS CISPR 22, AS/NZS 61000.4.3
 C US MC173467	CAN/CSA C22.2 No. 61010-1-04 UL Std No 61010A-1

FCC Note: This equipment has been tested and found to comply with the limits for a Class A digital device, pursuant to Part 15 of the FCC Rules. These limits are designed to provide reasonable protection against harmful interference when the equipment is operated in a commercial environment. This equipment generates, uses, and can radiate radio frequency energy and, if not installed and used in accordance with the instruction manual, may cause harmful interference to radio communications. Operation of this equipment in a residential area is likely to cause harmful interference in which case the user will be required to correct the interference at his own expense.

Industry Canada Note

This Class A digital apparatus complies with Canadian ICES-003.

Cet appareil numérique de la classe A est conforme à la norme NMB-003 du Canada.

ISO 9001 Registration

In 1994, Ohaus Corporation, USA, was awarded a certificate of registration to ISO 9001 by Bureau Veritas Quality International (BVQI), confirming that the Ohaus quality management system is compliant with the ISO 9001 standard's requirements. On May 15, 2003, Ohaus Corporation, USA, was re-registered to the ISO 9001:2000 standard.

TABLE OF CONTENTS

1.	INTRODUCTION.....	EN-3
1.1	Description.....	EN-3
1.2	Features.....	EN-3
1.3	Safety Precautions.....	EN-3
2.	INSTALLATION.....	EN-4
2.1	Unpacking.....	EN-4
2.2	Installing Components.....	EN-4
2.2.1	Assembly.....	EN-4
2.3	Selecting the location.....	EN-4
2.4	Leveling the Balance.....	EN-4
2.5	Connecting Power.....	EN-5
2.5.1	AC Adapter.....	EN-5
2.5.2	Turning Power On and Off.....	EN-5
2.6	Initial Calibration.....	EN-5
3.	OPERATION.....	EN-7
3.1	Overview of Controls & Display Functions.....	EN-7
3.2	Button Control Functions.....	EN-9
3.3	Using the Button Control Functions.....	EN-10
3.3.1	Setting the Balance to Zero.....	EN-10
3.3.2	Taring.....	EN-10
3.3.3	Changing Units of Measure.....	EN-10
3.3.4	Changing Application Modes.....	EN-10
3.3.5	Printing Data.....	EN-10
3.3.6	Calibration.....	EN-10
3.4	Menu.....	EN-11
3.4.1	Menu Structure.....	EN-11
3.4.2	Menu Navigation.....	EN-12
3.4.3	Changing Settings.....	EN-12
3.5	Application Modes.....	EN-13
3.5.1	Weighing.....	EN-13
3.5.2	Parts Counting.....	EN-13
3.5.3	Percent Weighing.....	EN-14
3.5.4	Check Weighing.....	EN-15
3.5.5	Dynamic/Animal Weighing.....	EN-15
3.5.6	Gross, Net, Tare Weighing.....	EN-16
3.5.7	Totalize.....	EN-17
3.5.8	High Point.....	EN-17
3.5.9	Density.....	EN-18
3.5.10	Statistics.....	EN-25
3.3.11	Pipette Calibration.....	EN-28

TABLE OF CONTENTS (Cont.)

3.6	Additional Features.....	EN-30
3.6.1	Weigh Below	EN-30
3.7	Balance Settings	EN-30
3.7.1	Menu Setup	EN-30
3.7.2	Calibration.....	EN-31
3.7.3	Setup	EN-35
3.7.4	Readout	EN-35
3.7.5	Mode	EN-35
3.7.6	Unit.....	EN-36
3.7.7	Print.....	EN-37
3.7.8	RS232	EN-37
3.7.9	GLP Data.....	EN-37
3.7.10	GLP Print.....	EN-38
3.7.11	Reset	EN-38
3.7.12	Lockout.....	EN-39
3.7.13	End.....	EN-39
3.8	Sealing Access to the Balance Settings	EN-40
3.9	Printing Data	EN-40
4.	MAINTENANCE	EN-41
4.1	Calibration	EN-41
4.2	Cleaning	EN-41
4.3	Troubleshooting.....	EN-41
4.4	Service Information.....	EN-42
4.5	Parts	EN-42
4.6	Accessories.....	EN-42
5.	TECHNICAL DATA	EN-43
5.1	Drawings	EN-43
5.2	Specifications	EN-44
5.3	Capacity x Readability	EN-45
5.4	Communication	EN-45
5.4.1	Commands.....	EN-45
5.4.2	Connections.....	EN-46
	Limited Warranty.....	EN-47

1 INTRODUCTION

This manual contains installation, operation and maintenance instructions for the Ohaus Discovery balances. Please read the manual completely before using the balance.

1.1 Description

Ohaus Discovery balances are precision weighing instruments that will provide you with years of service if properly cared for. The Ohaus Discovery balances are available in capacities from 110 grams to 310 grams.

1.1.1 Model Name Designations

Example: DV214CD

DV = Product family abbreviation Discovery

214 = 210g model with 0.0001g readability

C = With internal calibration (AutoCal)

D = Dual range model

1.2 Features

The Ohaus Discovery balances include many application modes.

- Weighing, Parts Counting
- Animal Weighing
- Check Weighing
- Percent Weighing
- Totalization
- Density, G/N/T
- Pipette Calibration
- High Point, Statistics

Other Standard features include:

- Two line backlit LCD
- In-use cover
- RS232 interface
- Weigh below hook
- Automatic Internal Calibration
- Overload and Underload indicators
- Lock-out switch safeguards pre-set parameters
- Legal for Trade models
- AC Adapter operation (AC Adapter included)
- Adjustable feet and level bubble
- Anti static wipes

1.3 Safety Precautions

Please follow these safety precautions:

- Verify that the input voltage printed on the AC Adapter matches the local AC power supply
- Use the balance only in dry locations
- Do not operate the balance in hostile environments
- Do not drop loads on the pan
- Service should be performed only by authorized personnel

2 INSTALLATION

2.1 Unpacking

Carefully remove your Discovery balance and each of its components from the package. Save the packaging to ensure safe storage and transport.

2.2 Installing Components

Refer to the illustration and instructions below to identify and assemble your Discovery balance with its components. All components must be installed before using the balance.

2.2.1 Assembly

1. Open the side doors of the balance, then Install the Shield, Wind Ring and Pan as shown in the illustration.
2. Place the In-Use cover on the front panel of the balance.

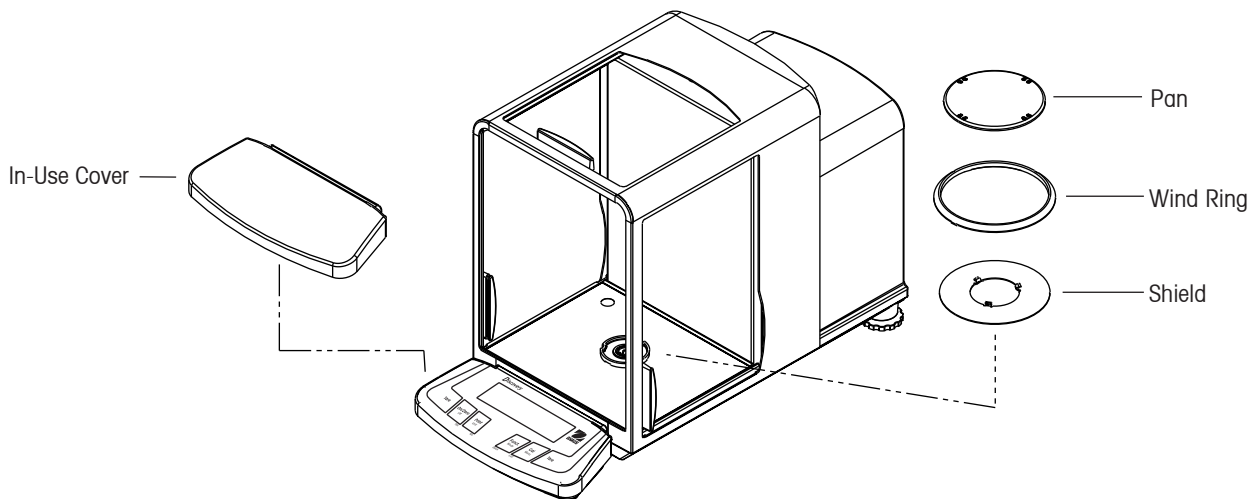

Installation of Balance Components

2.3 Selecting the Location

Locate the balance on a firm, steady surface. Avoid locations with excessive air currents, vibrations, heat sources, or rapid temperature changes.

2.4 Leveling the Balance

Before the balance is used, the feet should be adjusted so that the scale is level with the surface. This will enable accurate weighing. You will see a level bubble indicator in a small round window inside the weighing compartment. Level the balance by adjusting the leveling feet so the bubble is centered in the circle, as shown below.

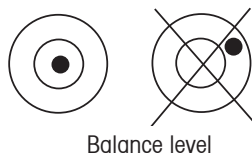

2.5 Connecting Power

2.5.1 AC Adapter

Connect the AC Adapter to the wall outlet. Connect the plug into the receptacle on the rear of the balance.



For use with CSA Certified (or equivalent approved) power source, which must have a limited circuit output.

2.5.2 Turning Power On and Off

Press the **On/Zero** button to turn power on.

The balance performs a segment check. The balance then displays the last selected application mode.

To turn power off, press and hold the **Off** button until OFF is displayed, then release the button.



2.6 Initial Calibration

When the balance is first installed, and when it is moved to another location, it must be calibrated to ensure accurate weighing results. The Discovery balance has built in Advanced AutoCal which can calibrate the balance automatically and does not require calibration masses. If preferred, the balance can be manually calibrated with external masses. Have the appropriate calibration masses available before beginning calibration. Refer to Section 3.7.2 for masses and calibration procedure.

IMPORTANT:



Balance should acclimate to its new surroundings for at least 8 hours. Balance electronics should be warmed up for 2 hours prior to use.

3 OPERATION

3.1 Overview of Controls & Display Functions

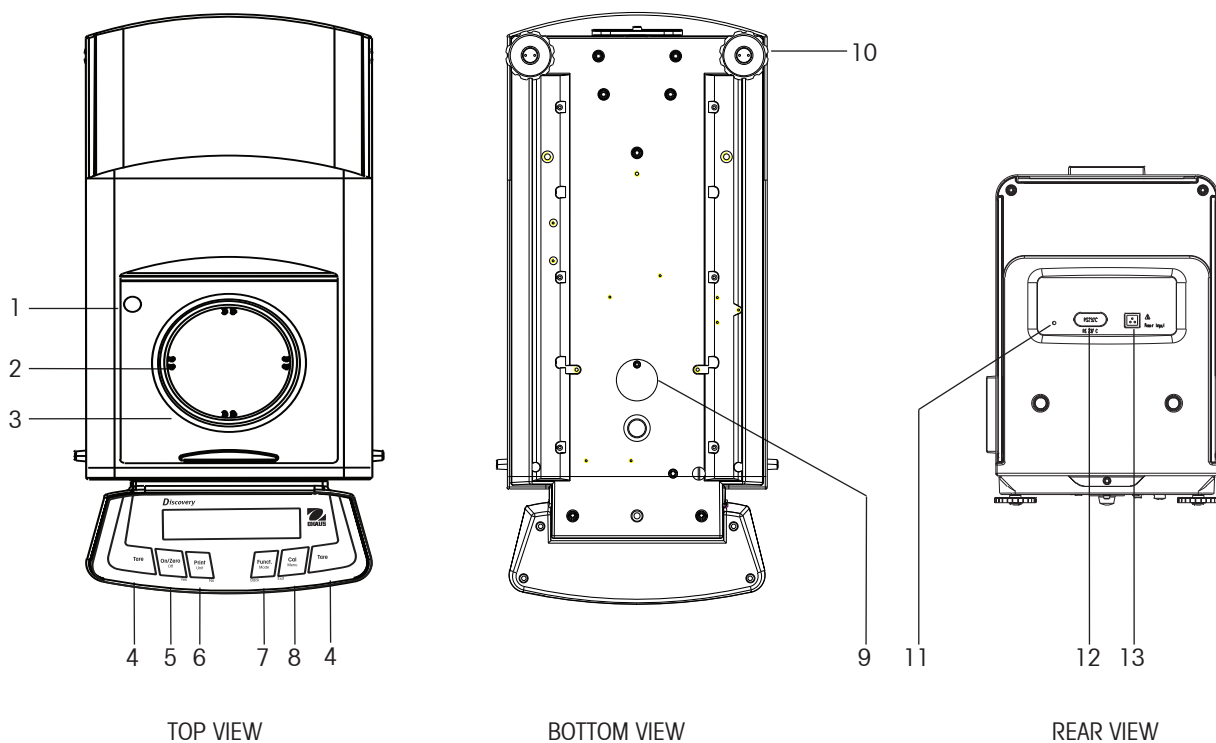
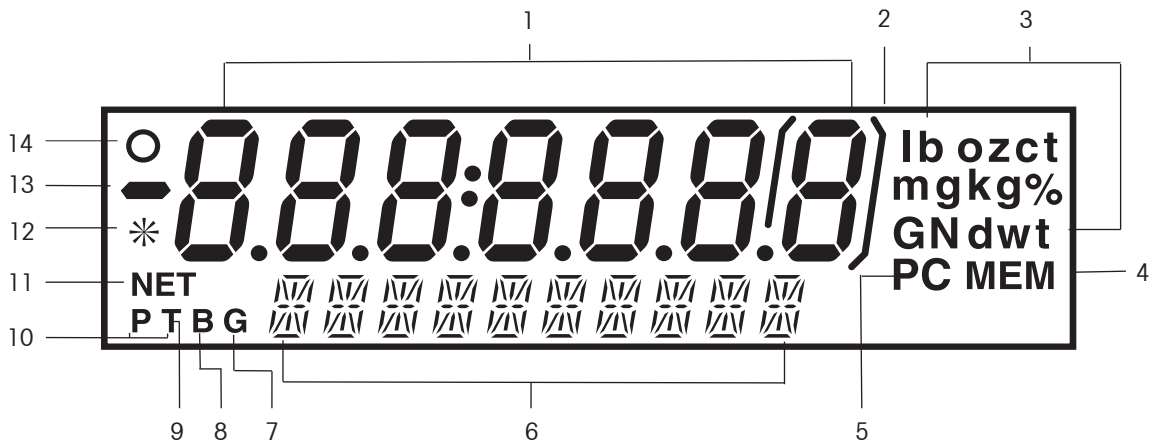

TABLE 3-1. DISCOVERY CONTROL FUNCTIONS.

1	Level Bubble
2	Pan
3	Wind Ring
4	Tare Buttons
5	On / Zero Off Button
6	Print Unit Button
7	Function Mode Button
8	Calibrate Menu Button
9	Weigh Below Cover and Screw
10	Leveling Feet
11	Lockout Reset Switch
12	COM 1 Connector
13	Power Connector

3.1 Overview of Controls & Display Functions (Cont.)



Digital Display Window

TABLE 3-2. DISCOVERY DISPLAY FUNCTIONS.

1	Primary (7 Segment) Display
2	Brackets
3	Units of Measurement
4	Memory Indicator
5	Pieces Indicator
6	Secondary (14 Segment) Display
7	Gross Indicator
8	Brutto Indicator
9	Tare Indicator
10	Preset Tare Indicator
11	Net Indicator
12	Stability Indicator
13	Negative Indicator
14	Center of Zero Indicator

3.2 Button Functions

Four multifunction buttons and two tare buttons are used to operate the balance and navigate the menus. The function of each button is shown below.

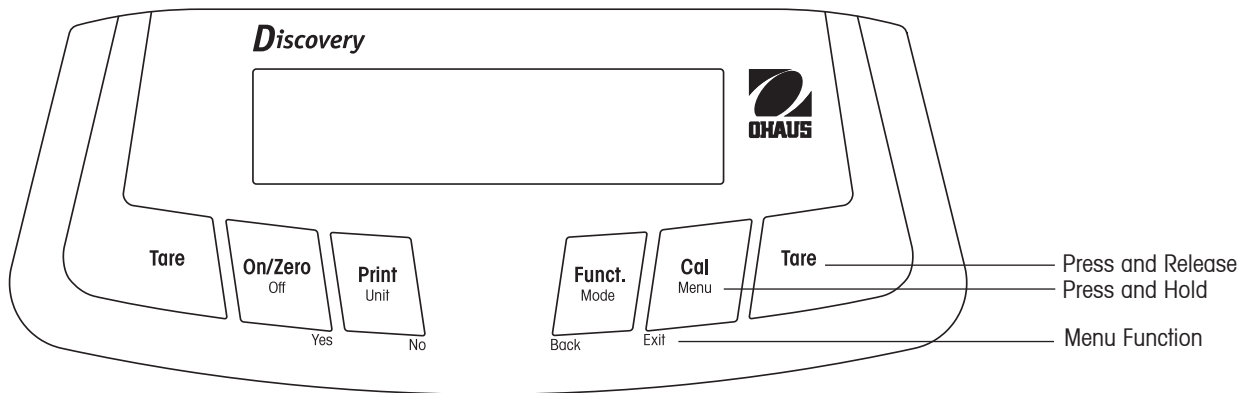

Primary Function	Tare <ul style="list-style-type: none"> Performs tare operation. 	On/Zero <ul style="list-style-type: none"> If balance is off, turns balance on. Zeros balance. 	Print <ul style="list-style-type: none"> Sends the current display value to the serial interface. 	Function <ul style="list-style-type: none"> Operation is dependent on the application mode. 	Cal <ul style="list-style-type: none"> Initiates calibration function.
Secondary Function		Off <ul style="list-style-type: none"> Turns balance off. 	Unit <ul style="list-style-type: none"> Change weighing unit. Press and hold will scroll through units. 	Mode <ul style="list-style-type: none"> Change application mode. 	Menu <ul style="list-style-type: none"> Press and hold allows entering the menu.
Menu Function		Yes <ul style="list-style-type: none"> Accepts the current (blinking) setting on the display. When editing in the alpha-numeric field, increments to the next digit. 	No <ul style="list-style-type: none"> Rejects the current setting (blinking) on the display. Increments a value being entered. 	Back <ul style="list-style-type: none"> Reverts back to the previous menu item. Decrements a value being entered. 	Exit <ul style="list-style-type: none"> Immediately exits menu mode. Aborts calibration in progress.

3.3 Using the Button Control Functions

3.3.1 Setting the Balance to Zero

Remove the load from the pan and press the **Zero** button to set the display to zero.

When the weighing pan is empty, the Center of Zero indicator turns on when the measurement is within + 1/4 division (d) of the zero setting.

3.3.2 Taring

Taring refers to the action of allowing for the weight of a container so that only the weight of objects held in the container (net weight) is displayed.

To Tare

Place the empty container on the pan and press the **Tare** button.

Add material to the container. The net weight of the material is displayed.

To clear the Tare value, remove the container from the pan and press the **Tare** button.

Auto Tare

Auto Tare automatically tares the first item placed on the pan.

Auto Tare must be set ON in the Setup sub-menu (See Section 3.7.3 Setup Sub-menu).

The secondary display shows CONTAINER (blinking). When the container is placed on the pan, it is automatically tared and Net weight is displayed. The Tare value is automatically cleared when the container is removed from the pan.

Preset Tare

A preset tare may be entered by using a computer connected to the COM 1 Connector. To enter a Preset Tare, send the xT command to the balance where x is the value in grams. Enter a value of 0 to clear the preset tare.

3.3.3 Changing Units of Measure

The Discovery balance can be configured to measure in a variety of units, including custom units. The Unit Sub-menu is used to enable or disable a specific unit.

To select a unit of measure:

Press and hold the **Unit** button, then release it when the desired unit is displayed.

Note: If the desired unit is not displayed, it must be turned on in the Unit menu (See Section 3.7.6).

3.3.4 Changing Application Modes

The Discovery balance can be configured to operate in various application modes. The Mode Sub-menu is used to enable or disable a specific application mode.

Press and hold the **Mode** button and release it when the desired mode is shown on the secondary display. **Note:** If the desired mode is not displayed, it must be turned on in the Mode menu. (See Section 3.7.5).

3.3.5 Printing Data

Press the **Print** button to send the displayed value to the COM port (See Section 3.10).

3.3.6 Calibration

Press the **Cal** button to enter the calibration mode. (See Section 3.7.2).

3.4 MENU

3.4.1 Menu Structure

The Discovery balance menu structure is illustrated below.

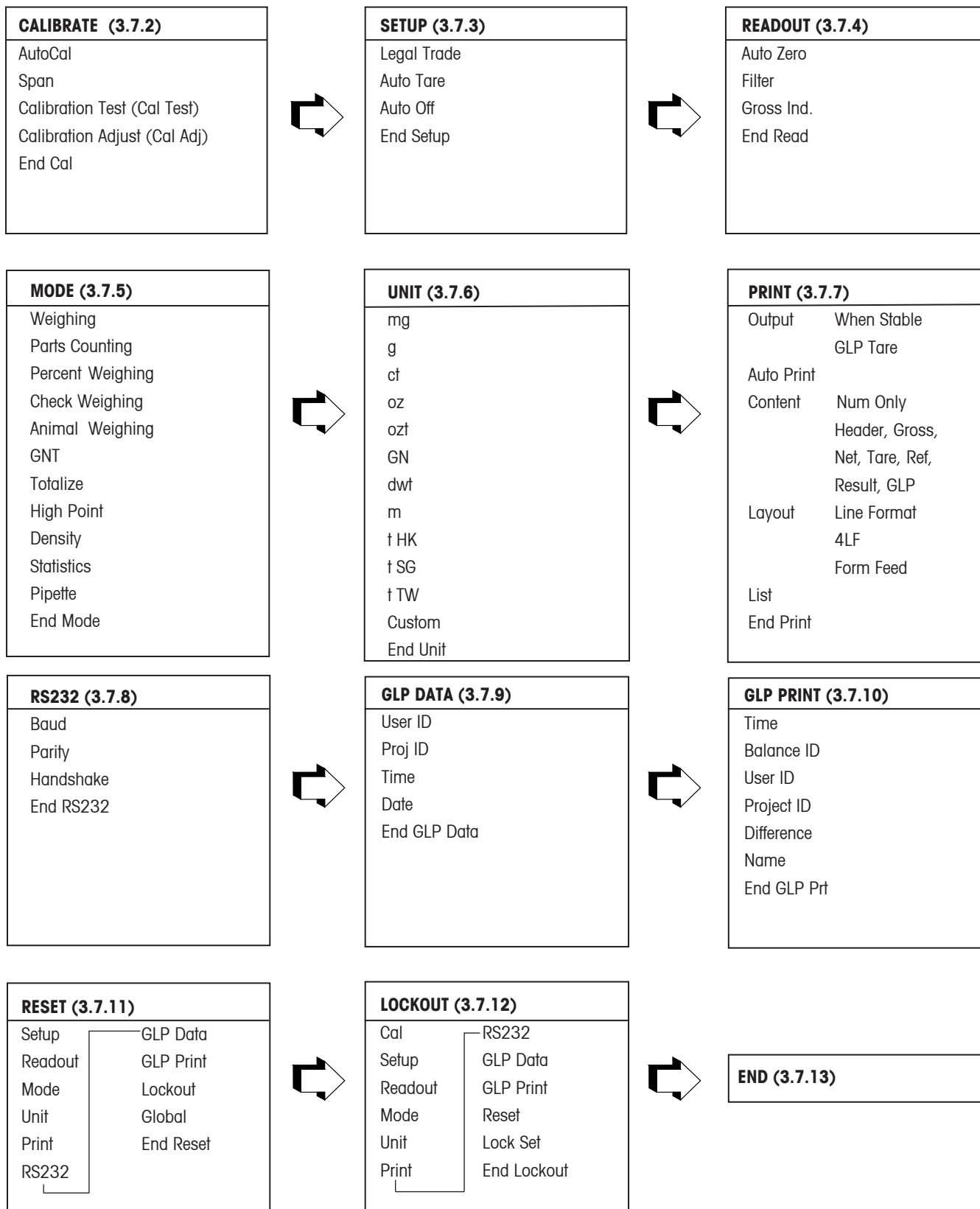

3.4.2 Menu Navigation

The Discovery menu structure consists of three levels. The top level is the main menu which consists of a number of sub-menus.

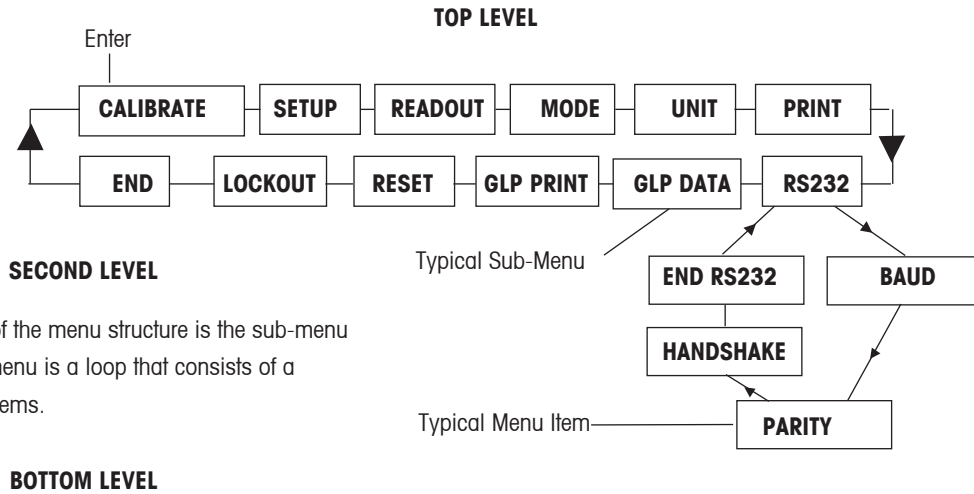

The second level of the menu structure is the sub-menu level. Each sub-menu is a loop that consists of a number of menu items.

The bottom level of the menu structure is the menu item level. Each menu item level consists of two or more settings

3.4.3 Changing Settings

To change a menu setting, perform the following steps:

ENTER THE MENU

Press and hold the **Menu** button until MENU appears on the primary (7-Segment) display. Release the button and the first sub-menu appears on the secondary display (14-Segment) Calibration (blinking).

Note: When the secondary display is blinking, press **Yes** to accept. Press **No** or **Back** or view another selection.

SELECT THE SUB-MENU

Press the **No** button to select the next sub-menu or the **Back** button to select the previous sub-menu in the loop. Press the **Yes** button to select the sub-menu that appears on the secondary display (blinking). The sub-menu name now appears on the primary display and the first menu item in the sub-menu now appears on the secondary display (blinking).

SELECT THE MENU ITEM

Press the **No** button to select the next setting or the **Back** button to select the previous setting in the loop. Press the **Yes** button to select and save the setting on the secondary display (blinking) as the new menu item setting.

EXIT THE MENU

Press the **Exit** button at any time to quickly exit the menu or select END sub-menu and press the **Yes** button.

3.5 Application Modes

The Discovery balance incorporates Weighing, Parts Counting, Percent Weighing, Check Weighing, Animal/Dynamic Weighing, Gross/Net/tare Weighing, Totalize, High Point, Density, Statistics and Pipette application modes. The default setting has the weighing mode turned on and all other application modes turned off.

Note: Before using any application modes, they must be turned on in the Mode menu (See Section 3.7.5).

3.5.1 Weighing

Use this mode to determine the weight of items in the selected unit of measure. The Discovery balance is shipped with grams enabled. Before using other units of measure, these units must be turned on in the Unit menu (See Section 3.7.6).

Weigh

Press and hold **Mode** until the display shows WEIGH, then release the button.

Press **Zero** to zero the balance.

Place objects to be weighed on the pan to display the weight.

The example displays a 200 gram weight in grams unit of measure



3.5.2 Parts Counting

Use the Parts Counting Mode to count samples of uniform weight.

Press and hold **Mode** until MODE COUNT is displayed, then release the button.



Establish an Average Piece Weight (APW).

Each time a new type of part is counted, the nominal weight of one piece (Average Piece Weight) must be established using a small quantity of pieces. This APW is stored until replaced by another APW.

When entering parts counting from another mode, CLEAR APW? (blinking) will appear in the lower display.

Press **No** to use the previously saved APW.

Otherwise, press **Yes** to establish a new APW.



The current weight (0.0000) is shown on the primary display and the default sample size (PLACE 10) is shown on the secondary display.



To change the sample size, press and hold the **No** button to increment the sample size through the range of 1 to 99. A short press will increment size by 1, a long press will increment size by 10. Release the button when the desired sample size appears on the secondary display. **Back** button for reverse.

Place the specified number of parts on the pan.

A short press of the **Function** button will accept the sample size and calculate the APW. The primary display will now indicate the number of parts. The weight is shown on the secondary display.



3.5.2 Parts Counting (Cont.)

Pressing the **Function** button displays the APW on the secondary display. The example shows an APW of 2.000g. Press the **Function** button again to return to Parts Counting Mode.



To establish a new APW from Count Mode, press **Mode** until COUNT appears. Press **No** to increment, **Back** to decrement, **Exit** to leave without saving and press **Yes** to accept.

APW Optimization

The only adjustment for Parts Counting is APW Optimization. APW Optimization is set On or Off in the Mode menu when Parts Counting is turned On. When APW Optimization is set on, the APW is automatically optimized. This results in more accurate parts counting. The factory default is On.

When a new APW has been established, APW Optimization occurs when the number of pieces added to the pan are between one and three times the number already on the pan. The secondary display will momentarily indicate APW OPT.

3.5.3 Percent Weighing

Use the Percent Weighing Mode to measure the weight of a sample as a percentage of a pre-established reference weight. Refer to Section 3.7.5 to enable Percent Weighing. Press and hold **Mode** button until MODE PERCENT is displayed



To Establish a Reference Weight

PERCENT is displayed with CLEAR REF? (blinking). Press the **No** button to use the stored reference weight and begin Percent Weighing.



Press **Yes** to continue. PUT SAMPLE (blinking) will be shown on the display.

Place the sample on the pan and press the **Function** button. The balance indicates the sample weight on the primary display as 100%. The actual sample weight is shown on the secondary display. This example illustrates 20 grams as the reference weight.



Remove the reference weight and place the item to be compared on the pan. The balance indicates the actual percentage on the primary display. The secondary display indicates the weight in the selected measuring unit.



Pressing the **Function** button momentarily displays the reference weight on the secondary display. Pressing the **Function** button a second time will return to the actual weight.

Establish New Reference Weight

Press and hold the **Mode** button until PERCENT is shown on the secondary display. PUT SAMPLE will blink on the lower display. Add new reference weight and press **Function** button to accept new 100% reference.

3.5.4 Check Weighing

Check Weighing is used to compare the weight of a sample against target limits.

Press and hold **Mode** button MODE CHECK is displayed, then release the button.



To Establish Check Weighing Parameters

CHECK is displayed with CHG PARAM? (blinking). Press the **No** button to use the stored limits and begin Check Weighing, or press **Yes** to set Check Weighing limits.



Setting Under and Over Limits

The primary display shows UNDER or OVER indicating which limit is being entered. The secondary display shows the previous setting (blinking). Press the **Yes** button. The primary display shows UNDER. The secondary display indicates the previous entry with the first digit (blinking). Press the **Yes** button to accept the digit and advance to the next digit. Press the **No** button and **Back** button to edit the setting. The Under Limit is the first to be edited followed by the Over Limit. Press the **Yes** button to accept the limit settings. To skip quickly to the end of settings, press **Exit**.



Editing Limits

The limits are edited one digit at a time. The digit being edited is blinking. Its value can be incremented by pressing the **No** button or decremented by pressing the **Back** button. When the desired value is displayed, press the **Yes** button to accept the value and proceed to the next digit. When all digits have been edited, the new limit value is shown (blinking) on the secondary display. Press the **Yes** button to accept the limit settings.



When editing of the Over limit is complete, Check Weighing begins.

Place the sample on the pan. The UNDER/ACCEPT/OVER status is shown on the primary display while the actual weight of the item is shown on the secondary display.



To Establish New Check Weighing Parameters

Press and hold the **Mode** button until CHECK is shown on the secondary display.

3.5.5 Dynamic/Animal Weighing

Enter this mode to weigh an unstable load, such as a moving animal. Refer to Section 3.7.5 to enable Animal Weighing and set Filter to either Low, Medium or High, the default is Medium.

Press and hold **Mode** button, MODE ANIMAL is displayed, then release the button.



To Establish Animal Weighing Parameters

ANIMAL CHG PARAM? (blinking) is displayed. Press the **Yes** button. MODE SET SEMI (blinking) is displayed.



NOTE: SET AUTO, SET SEMI or SET MANUAL may be displayed initially depending upon previous settings.



Press the **No** button to change the setting and **Yes** to accept. The balance shows READY on the secondary display.



3.5.5 Dynamic/Animal Weighing (Cont.)

Automatic Mode

Place subject on the pan, the balance will automatically start a countdown. At the end of the countdown period, the subject weight is displayed. The balance returns to the ready condition when the animal is removed from the pan. If the **Function** button is pressed before the animal is removed from the pan, the primary display shows the actual weight and the secondary display shows CLEAR PAN until the animal is removed from the pan. The balance then returns to the Ready condition.

Semiautomatic Mode

Place subject on the pan, the balance will automatically start a countdown. Remove the animal from the pan and press the **Function** button to return to the ready condition. If the **Function** button is pressed while the animal is on the pan, the primary display shows the actual weight and the secondary display shows CLEAR PAN. The balance returns to the Ready condition when the animal is removed from the pan.



Manual Mode

Place subject on the pan and press the **Function** button, the balance will start a countdown. Remove the animal from the pan and press the **Function** button to return to the ready condition. If the **Function** button is pressed while the animal is on the pan, the primary display shows the actual weight and the secondary display shows CLEAR PAN. The balance returns to the Ready condition when the animal is removed from the pan.

During Animal Cycle

The primary display shows the countdown of the Filter Level setting (Low (5 sec) Medium (10 sec), High (15 sec). The secondary display shows BUSY. This Animal Filter setting is configured in the Mode menu when Animal Weighing is turned On.

Completed Animal Cycle

The primary display shows the weight of the animal and the secondary displays shows HOLD.

To Establish New Animal Weighing Parameters

Press and hold the **Mode** button until ANIMAL is shown on the secondary display.

3.5.6 Gross, Net, Tare Weighing

Gross/Net/Tare (G/N/T) application allows the balance to display Gross (sample plus container weight), NET (sample weight) and TARE (container weight). The primary display will show the reading of the net (or tare) weight. The secondary display will show the reading of the gross weight. Refer to section 3.7.5 to enable G/N/T weighing.

G/N/T Weighing

Press and hold **Mode** button, MODE GNT is displayed, then release button. Clear pan and press the **On/Zero** button to zero the balance before beginning.



Place a container on the pan then press the **Tare** button. The container's weight is stored in memory in the balance. Place the material in the container. The balance immediately calculates the Gross, Net and Tare weights.



A short press of the **Function Mode** button will toggle the 7 segment display to show the tare weight and the net weight. Example shown represents a container weight of 20g and material of 50g. The gross weight is displayed as 70g. Before a new container is used, zero the balance by using the **On/Zero** button. A short press of the **Print** button will print the G/N/T weights. Net and Tare have to be turned On in the Print Content sub-menu.



3.5.7 Totalize

Totalize measures the cumulative weight of items. Refer to Section 3.7.5 to enable totalizing.

Press the **Mode** button, then release when MODE TOTALIZE is displayed. The primary display shows the current weight.

To Establish Totalize Parameters

The primary display shows TOTAL and the secondary display shows CHG PARAM? (blinking). At this point you can select either a manual or automatic mode. Press the **Yes** button. MODE is shown in the primary display with SET MANUAL in the secondary display (blinking). Press the **No** button to change mode and **Yes** to accept.

Manual Mode

When entering the manual mode, the primary display shows the current weight, the secondary display shows the current totalized weight. Pan must be clear and stable before beginning process. secondary display will blink when balance is ready to begin totalizing weights.

Place the item on the pan. Press the **Function** button to add the weight of the item to the total. The new total is shown on the secondary display when stability is reached.

Remove the item from the pan. Balance must be stabilized at zero before next item can be placed. The primary display indicates the current weight on the pan. The secondary display indicates the total accumulated weight.

Add the next item and press the **Function** button. The display shown indicates a cumulative weight of 70 grams. Remove item from pan and repeat process for each new item.

Automatic Mode

After entering the automatic mode, place the item on the pan. The weight of the item is shown on the primary display. The secondary display will show BUSY (blinking) after the item is added until the balance is stabilized and then shows the new total on the secondary display. Remove the item from the pan. Balance must be stabilized at zero before next item can be placed, then add the next item.

To Establish New Totalize Parameters

Press and hold the **Mode** button until TOTALIZE is shown on the secondary display.

3.5.8 High Point

The High Point Mode allows the user to capture and store the highest (stable) weight in a series of weight measurements. Refer to Section 3.7.5 to enable High Point mode. Press the **Mode** button until HI POINT is shown on the secondary display. When set On, the primary display will indicate the current weight reading, the secondary display will indicate the highest weight reading. The example indicates a current weight of 50.0000 g and a high point reading of 55.0000 g. Press **Function** button to view lowest reading in memory.

To reset High Point and clear memory, press and hold **Mode** until High Point is shown on lower display.



3.5.9 Density

Refer to section 3.7.5 to enable density measurements. Follow the procedures as indicated after initial setup in Section 3.7.5. Read the information concerning density measurements after the procedure which references an Ohaus Kit used specifically for density measurements.

Four methods of density determinations can be made with the Discovery balance. These are:

1. Solids more dense than water,
2. Solids less dense than water,
3. Liquid density,
4. Porous material (impregnated with oil).

A Density Determination Kit Part Number 80850045 is designed to be used with Ohaus Discovery balances. Illustrations in this procedure refer to the density kit, however, you may use whatever lab apparatus that will suit the requirements for density measurements. A built in reference density table for water at temperatures between 10°C and 30°C is included in the balance software. Review this entire section before attempting density measurements.

When making density measurements, the material should weigh at least 10.0 mg on an analytical balance and 100 mg on a precision balance.

Balance Preparation with Ohaus Density Kit (Optional)

Allow the balance to warm up sufficiently before making measurements.

Open either the left or right side door of the balance and remove the Pan as shown. Insert the Bracket into the balance where the Pan was removed.

The Equalizing Washer is not used.

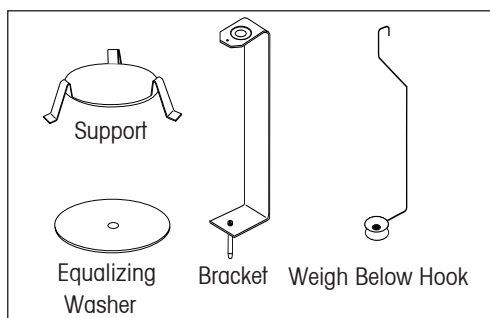

Kit Components

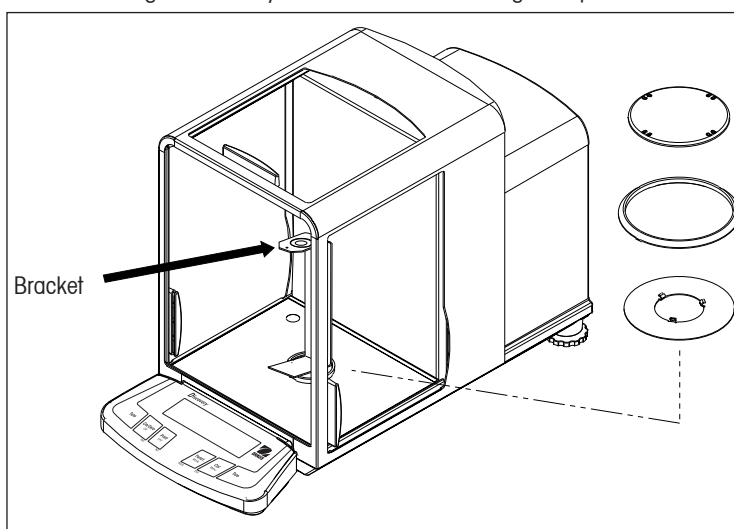

Balance Preparation

Place the Support into position over the bracket making sure the Support does not make contact with the Bracket as shown in illustration.

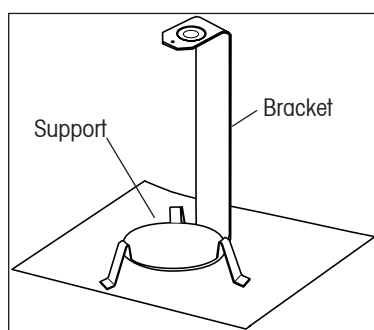

Support Mounting

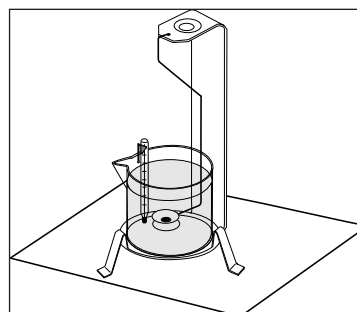

Beaker Installation

Install beaker on support as shown.

NOTE: Beaker and thermometer are not supplied as part of the density kit.

3.5.9 Density (Cont.)

The density Q is the quotient of the mass m and the volume V.

$$Q = \frac{m}{V}$$

Density determinations are performed by using Archimedes' principle. This principle states that every solid body immersed in a fluid loses weight by an amount equal to that of the fluid it displaces. The density table for water is included in the Discovery balance software.

The density of a solid is determined with the aid of a liquid whose density, Q₀, is known (water is used as an auxiliary liquid). The solid is weighed in air (A) and then in the auxiliary liquid (B). The density Q can be calculated from the two weighings as follows:

$$Q = \frac{A}{A - B} \cdot Q_0$$

The balance allows direct determination of the buoyancy P (P = A - B) and consequently the above formula can be simplified:

$$Q = \frac{A}{P} \cdot Q_0$$

Q = Density of the solid

A = Weight of the solid in air

B = Weight of the solid in the auxiliary liquid

Q₀ = Density of the auxiliary liquid at a given temperature (this value depends on the temperature). The density table for water is included in Discovery balances.

P = Buoyancy of the solid in the auxiliary liquid (corresponds to A - B).

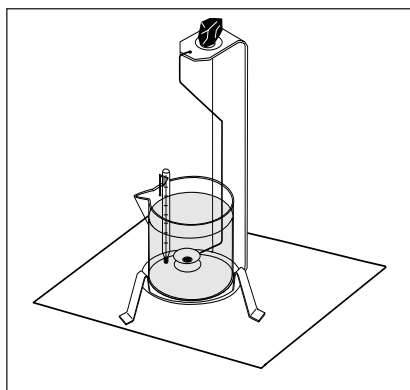

Sample Weighing in Air

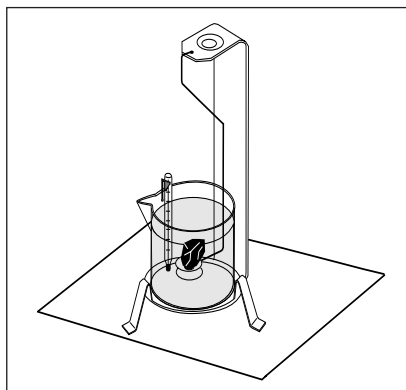

Sample Weighing in Liquid

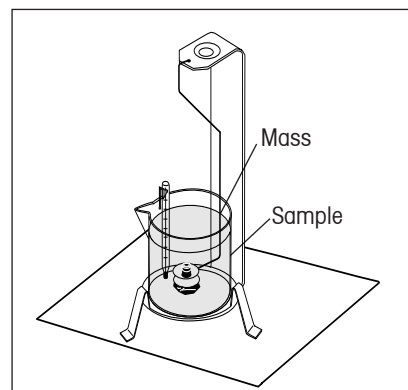

Buoyancy Sample Weighing

Place the solid in the Weighing Pan on the Weigh Below Hook in the liquid as shown. Ensure that there are no air bubbles on the solid to be weighed.

Close the draft shield doors and weigh the solid (buoyancy P). The display indicates the density in grams/cc.

3.5.9 Density (Cont.)

Solid Density Determinations for items Less Dense Than Water

For density determination of solids with a density less than

1 g/cm³, the bottom of the Weigh Below Hook for solids must be used as it holds the solid body below the surface of the auxiliary liquid. If the buoyancy of the solid is greater than the weight of the Weigh Below Hook, the Weigh Below Hook must be weighted by placing an additional mass on the submerged part of the Weigh Below Hook as shown.

Weigh the sample in air first as explained in the previous procedure.

After loading the additional mass, tare the balance and start the weighing again. Wait until the balance has reached stability and note the displayed weight **P** (buoyancy of the solid).

Improving the Accuracy of the Result of Solid Density

The following tips should help you improve the accuracy of the results in the density determination of solids.

Temperature

Solids are generally so insensitive to temperature fluctuations that the corresponding density changes are of no consequence. However, as work is performed with an auxiliary liquid in the density determination of solids, their temperature must be taken into account as the temperature has a greater effect with liquids and causes density changes in the order of magnitude 0.1 to 1% per °C. This effect is already apparent in the third decimal place of the result.

To obtain accurate results, we recommend that you always take the temperature of the auxiliary liquid into account on all density determinations.

Air Buoyancy

1 cm³ of air weighs approximately 1.2 mg (depending on the physical condition). As a consequence, in the weighing in air, each solid experiences a buoyancy of this magnitude (the so-called "air buoyancy") per cm³ of its volume.

However, the air buoyancy must be taken into account only when a result is required with an accuracy of 3 to 4 decimal places. To correct for this, the air buoyancy (0.0012 g per cm³ volume of the body) is added to the calculated result:

$$\text{Calculated density} + 0.0012 \text{ g/cm}^3 \text{ air buoyancy} = \text{effective density}$$

Surface tension of the auxiliary liquid

Adhesion of the liquid to the Weigh Below Hook causes an apparent weight increase of up 3 mg.

As the Weigh Below Hook is immersed in the auxiliary liquid in both weighings of the solid (in air and in the auxiliary liquid), the influence of the apparent weight increase can be neglected because the balance is tared before every measurement.

To reduce the effect of air bubbles and to ensure the greatest possible accuracy, use a few drops of a wetting agent (not supplied) and add them to the auxiliary liquid.

3.5.9 Density (Cont.)

Liquid Density Determinations

The density of a liquid can be made using a sinker of known volume. The sinker (sinker is not included in the kit) is weighed in air and then in the liquid whose density is to be determined, The density, Q, can be determined from the two weighings as follows:

$$Q = \frac{A - B}{V}$$

- Q = Density of the liquid
- A = Weight of the sinker in air
- B = Weight of the sinker in liquid
- V = Volume of the sinker
- P = Buoyancy of the sinker in the liquid
- (P = A-B)

In DENSITY SETUP, set Mode to Liquid Density and enter sinker volume in cc's.

After weighing the sinker in air and then weighing the sinker immersed in liquid, the balance calculates the density of the liquid and is displayed in grams/cc. See illustrations below for placement of the sinker. When the sinker is immersed in the liquid, it must not come into contact with the bottom of the beaker.

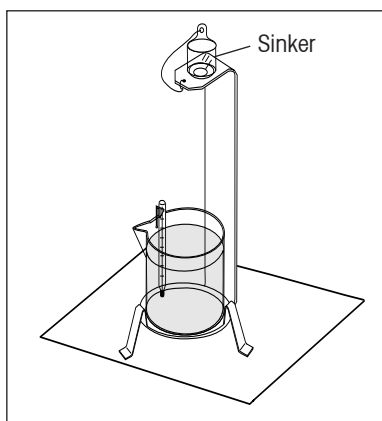

Sinker in Air

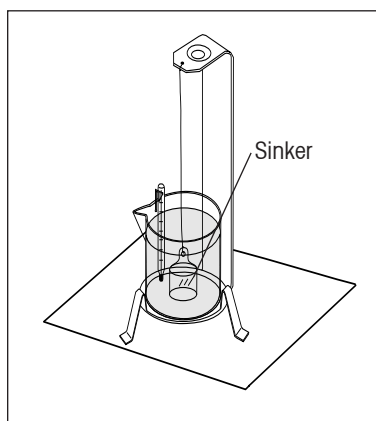

Sinker in water

Porous Material Density Determinations

The density of a porous (oil impregnated part) can be made with the balance. Weigh the part (dry) prior to oil impregnation and record its weight. You must also know the density value of the oil to be used in immersing the part before starting. In this procedure, you will follow the method for solid density measurements using water.

Enter the dry weight of the porous material and the density of oil used to impregnate the part.

To Determine Wet Density

Wet density of the sample can be calculated by following the normal Solid Density procedure using the oil impregnated part.

3.5.9 Density (Cont.)

Before density measurements can be made, the density mode of operation must be set up in the Menu, Mode Sub-menu. It is in the Mode Sub-menu where solid, porous, water or auxiliary liquids are selected.

After the basic parameters have been set, the balance density operation is further determined in the APPL DENSITY menu. This menu allows the setting of Density, Temperature, Dry Weight of Porous Material, Sinker Volume and Density of Oil.

To Perform a Density Measurement

Refer to paragraph 3.7.5 for density set-up procedures.

A. Measuring the Density of a Solid Using Water

The following menu items should be turned on: SOLID, WATER.

Press and hold **Mode** until MODE DENSITY appears, DENSITY CHG PARAM? is displayed.



Press the **Yes** button, TEMP 20.00 C (blinking) is displayed. Measure the temperature of the water with a precision thermometer and enter the temperature using the **Yes**, **No** and **Back** buttons. When the last digit is entered, press the **YES** button to save.



The balance indicates 0.0000 IN AIR (blinking). Weigh the sample in air and press the **Function** button.



Now, weigh the sample in water (liquid) and press the **Function** button. The balance displays the result in grams per centimeter (g/cc). Typical samples are shown.



To Establish New Density Parameters

Press and hold the **Mode** button until DENSITY is shown on the secondary display.



B. Measuring the Density of a Buoyant Material Using Water

The following menu items should be turned on: SOLID, WATER.

Follow the same procedure in A except refer to Buoyancy Sample weighing illustrations and place sample as shown.

3.5.9 Density (Cont.)

C. Liquid Density using Calibrated Sinker (Not supplied)

The following menu item should be turned on: LIQUID.

Press and hold the **Mode** button until MODE DENSITY is displayed, then release the button. DENSITY CHG PARAM? is displayed.



Press the **Yes** button VOLUME 00.000000 is displayed. Enter the volume of the sinker, use the **Yes**, **No** and **Back** buttons.



The balance indicates 0.0000g IN AIR (blinking). Place the sinker on the pan and press the **Function** button.



Place the sinker in the beaker (in liquid) as shown in previous illustration and press the **Function** button. The balance displays the result in grams per centimeter (g/cc).



To Establish New Density Parameters

Press and hold the **Mode** button until DENSITY is shown on the secondary display.

D. Density of Solid using Auxiliary Liquid

The following menu items should be turned on: SOLID, AUXILIARY.

Press and hold **Function** button until MODE DENSITY is shown. DENSITY CHG PARAM? is displayed.



Press the **Yes** button, DENSITY 0.000000 is displayed. Enter the density value of the auxiliary liquid being used from a density table, use the **Yes**, **No** and **Back** buttons.



When the proper density value has been entered, press the **Yes** button.



The display now indicates TEMP 00.00 C (blinking). Enter the measured temperature of the auxiliary liquid with a precision thermometer and enter the value using the **Yes**, **No** and **Back** buttons, then press the **Yes** button.



3.5.9 Density (Cont.)

D. Density of Solid using Auxiliary Liquid (Cont.)

The balance now indicates 0.0000 g IN AIR (blinking). Place the sample on the support and weigh in air, press the **Function** button.



Carefully submerge the sample in the auxiliary liquid (in liquid) using the kit and press the **Function** button. The balance displays the result in grams per cubic centimeter (g/cc).



To Establish New Density Parameters

Press and hold the **Mode** button until DENSITY is shown on the secondary display.



NOTE: Sample illustrations values are not correct and are to be used as a guide only.

E. Density of Porous Material Using Oil



NOTE: Before starting this procedure, weigh the porous sample and record the dry weight. This is important as you will have to enter this value later on.

The following should be turned On in the Setup Menu: POROUS, WATER.



Press and hold the **Mode** button until DENSITY is shown on the secondary display..

Press the **Yes** button, TEMP 20.00 C is displayed. Enter the water temperature from a precision thermometer, then press the **Yes** button.



WEIGHT 00.00000 is displayed. Enter the weight of the porous material previously recorded, then press the **Yes** button.



D OIL 0.000000 is displayed. Enter the density of the oil, then press **Yes**.



The balance indicates 0.0000g IN AIR (blinking). Immerse the porous material in oil to saturate it and weigh, press the **Function** button.

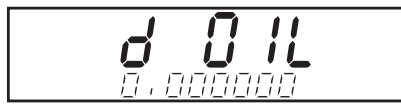

Now, immerse the porous material in water (in liquid) and press the **Function** button. The balance displays the result in grams per cubic centimeter (g/cc).



To Establish New Density Parameters

Press and hold the **Mode** button until DENSITY is shown on the secondary display.



NOTE: Sample illustration values are not correct and are to be used as a guide only.



3.5.10 Statistics

Statistics are used when it is desired to compare a number of samples and examine the relative deviation of the samples along with other statistical data. A minimum of three samples is required in this program. When a printer or computer is connected to the balance, all statistical information can be observed and printed. Weighing, Animal Weighing and Check Weighing are the functions for providing Statistical Data.

Statistical Weighing

Refer to paragraph 3.7.5 for statistics set-up procedures.

Press and hold the Mode button until STATS is shown in the secondary display. STATS CHG PARAM? (blinking) is displayed. Press the **Yes** button. SAMPLE SIZE 3 is displayed. Pressing the **No** button increments the sample size and pressing the **Back** button decrements the sample size. When the desired number of samples has been set, press the **Yes** button.

The display will change to 0.0000 g SAMPLE 1 (blinking).

Place the first sample on the pan and press the **Function** button. The display will show BUSY for a few seconds and then display the weight of the first sample and SAMPLE 2 will be blinking on the display.

Continue the procedure until all samples have been weighed. After the last sample has been weighed, the display will indicate the Deviation of all samples.

By pressing the **Function** button repeatedly, you can observe the Deviation, Relative Deviation, Mean, Sum, Maximum and Minimum readings.

To Establish Statistical Weighing Parameters

Press and hold the **Mode** button until STATS is shown on the secondary display.

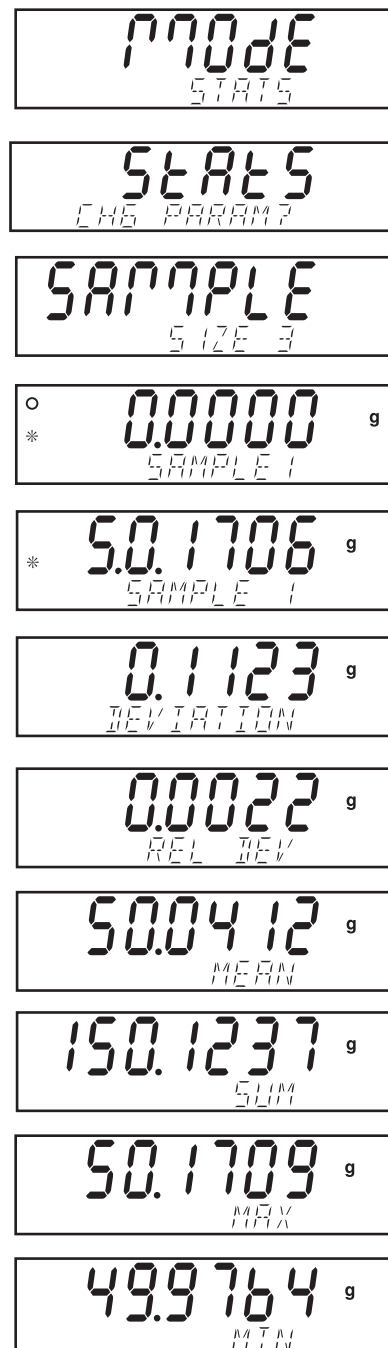

3.5.10 Statistics (Cont.)

Statistical Check Weighing

Press and hold **Mode** button until STATS is shown on the secondary display.

For statistical Check Weighing, use the same general procedure as in Statistical Weighing.



UNDER 00.0000 g is displayed.



Using the **No** button to increment and the **Back** button to decrement and the **Yes** button to accept and advance to the next digit, proceed to enter the under value for samples. Press the **Yes** button to accept. The display changes to OVER 00.0000 g.



Using the **No**, **Back** and **Yes** button, enter the Over value. Press the **Yes** button to accept.

SAMPLE SIZE 3 is displayed on the sample illustration. The number will vary according to the number of samples set in the Menu.



Using the **No**, **Back** and **Yes** buttons, enter the desired sample size, in this case, 5 was used, then press the **Yes** button.

UNDER SAMPLE 1 is displayed. Place sample 1 on the pan, either UNDER, ACCEPT or OVER SAMPLE 1 appears on the display. In this case the sample illustration indicates ACCEPT SAMPLE 1. Press the **Function** button. Remove the first sample from the pan, the balance indicates UNDER SAMPLE 2. Place the second sample on the pan and press the **Function** button. Repeat this procedure for all of the samples.



When all of the samples have been entered, the display will indicate the Deviation.

By pressing the **Function** button repeatedly, the balance indicates the Relative Deviation, Mean, Sum, Maximum and Minimum readings of all samples.



To Establish Statistical Check Weighing Parameters

Press and hold the **Mode** button until STATS is shown on the secondary display.

3.5.10 Statistics (Cont.)

Statistical Animal Weighing

This procedure is very similiar in setup as Statistical weighing. Use the same general procedure.

Press and hold **Mode** button until STATS is shown on the secondary display. STATS CHG PARAM? (blinking) is displayed. Press the **Yes** button, SAMPLE SIZE 5 is displayed. Pressing the **No** button increments the sample size, **Back** button decrements the sample size. Pressing the **Yes** button accepts the digit and advances to the next digit. When the desired number of samples has been selected, press the **Yes** button.

The display will change to 0.0000 g SAMPLE 1.

Place the first sample on the pan, then press the **Function** button. The display will show the weight of the subject with a countdown period, then the weight of the subject with HOLD is displayed.

Press the **Function** button, the weight of the subject is displayed with CLEAR PAN. Remove the subject from the pan and place a new subject on the pan then press the **Function** button.

Continue this procedure until all samples have been weighed. After the last sample has been taken, the display will indicate the deviation.

By pressing the **Function** button repeatedly, the balance indicates the Relative Deviation, Mean, Sum, Maximum and Minimum readings off all samples.

To print statistical results, refer to Sections 3.7.7, 3.7.8, 3.7.9 and 3.7.10 to set up printing. Once setups are completed, press the **Print** button.

To Establish Statistical Animal Weighing Parameters

Press and hold the **Mode** button until STATS is shown on the secondary display.



3.5.11 Pipette Calibration

Pipette calibration checks the accuracy and precision values of pipettes by weight analysis. The balance is capable of recording data of each pipette tested. The density table for water is included. If other liquids are used for pipette calibration, you must enter the liquid’s density in g/cc at current room temperature. Since all calculations are made within the balance, it is also required that you know the atmospheric pressure. A printout can be made which specifies all parameters of the calibration made. Parameters include test liquid, liquid density, H2O temperature, barometer unit, barometer pressure, nominal and nominal units have to be set first.

Pipette calibration can be accomplished manually or automatically in the balance. Calculations made within the balance provide results of Inaccuracy and Imprecision.

To Establish Pipette Calibration

Refer to paragraph 3.7.5 for Pipette set-up procedures. Enable Pipette Mode in the Menu where the following parameters can be set (liquid, barometric pressure, etc.).



Press and hold **Mode** button until MODE PIPETTE is shown. Press the **Yes** button, MODE SET MANUAL is displayed. You can select either AUTO or MANUAL. Use the **No** button to change selection and **Yes** button to accept.



Press the **Yes** button, TEMP 25.00 c is displayed. Press the **No** button to increment digit edit field and **Back** button to decrement. Press the **Yes** button to save temperature value of the liquid used in the pipettes.



B PRESS 1.000 ATM is displayed as an example, if a different pressure unit was initially selected, you can now edit the value. Press the **Yes** button when finished with editing the value.



NOM 0.000 ML is displayed, the example illustrates ML was selected. You may now enter the Pipette dispensing value. For the purposes of this example, 0.330 ML was used and an Auto Mode was selected. This allows a faster method of results with limited handling of the balance. Use the **No**, **Back** and **Yes** buttons to edit the value.



Press the **Yes** button, INACC % 0.000000 is displayed. Enter the value shown on the Pipette specification into the balance using the **No**, **Yes** and **Back** buttons. The example illustrates 5.000000 %, press the **Yes** button.



3.5.11 Pipette Calibration (Cont.)

IMPREC % 0.000000 is displayed. Edit the value and press the **Yes** button. This value is specified on the Pipette. The example used was 5.000000 %. Press the **Yes** button to accept.



SAMPLE SIZE 10 is displayed. Using the **Yes**, **No** and **Back** buttons, change the sample size. The example shown uses 5 samples. When sample size is entered, press the **Yes** button.



The balance is now ready to accept samples. It is essential that the balance be located on a stable, vibration free surface and away from any drafts caused by heating and or cooling outlets. The balance is very sensitive to external influences. When samples are administered, the draft shield doors must be closed. Failure to adhere to these practices will result in incorrect results.

0.0000 g SAMPLE 1 (blinking) is displayed. Place the receptacle container on the pan and press the **Tare** button.



Place the first sample in the container, SAMPLE 1 will blink, press the **Function** button the display will now momentarily show the microliter value then tares out the value for the next sample. Place the remaining samples making sure the secondary display is indicating the next sample before placing it into the container. The weight of each sample is shown during the calculation period.



When all of the samples have been taken, the balance calculates the Inaccuracy and Imprecision either as a pass or fail in percentage. The examples shown here indicate passing.



Press the **Function** button to toggle between inaccuracy and imprecision displayed values.



To Establish New Pipette Parameters

Press and hold the **Mode** button until PIPETTE is shown on the secondary display.



3.6 Additional Features

3.6.1 Weigh Below

The Discovery balance is equipped with a weigh below hook.

Note: Before turning the balance over, remove the pan, wind shield and shield to prevent damage to the glass doors.

To use this feature, remove power from the balance and remove the protective cover for the weigh below opening as shown. Install the weigh below hook.

The balance can be supported using lab jacks or any other convenient method. Make sure the balance is level and secure. Use a string or wire to attach items to be weighed.

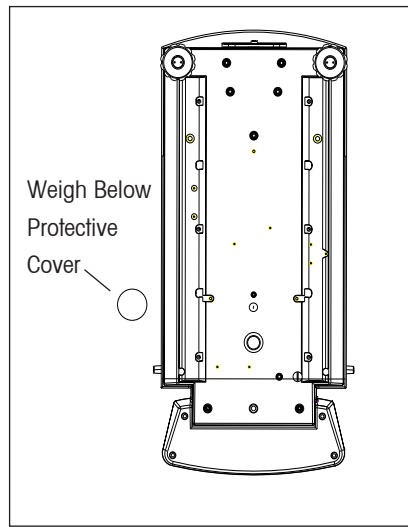

Bottom View of Balance

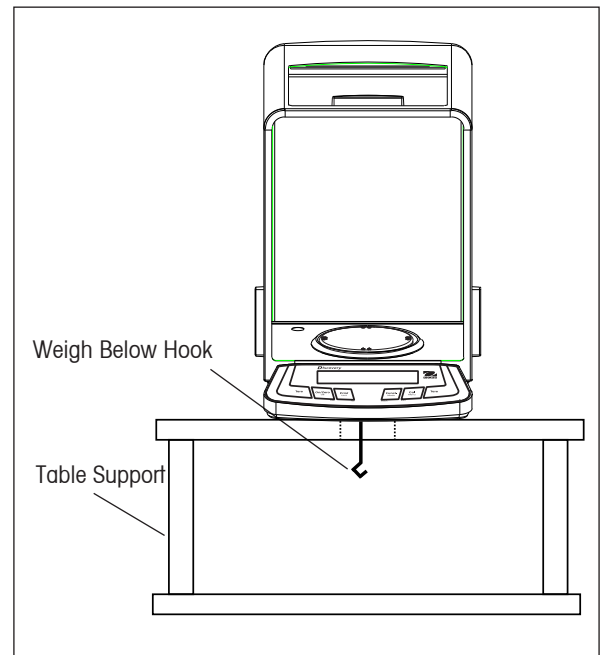

Balance With Weigh Below Hook Installed

3.7 Balance Settings

3.7.1 Menu Setup

Pressing the **Menu** button allows access to the menus shown below. Each menu contains additional sub-menus that are used to set the balance parameters. This section of the manual contains all menus and descriptions required to set all parameters for the Discovery balance. Please review the contents of each menu to get a better understanding of the balance's capabilities before attempting to operate the balance. The diagram below illustrates the main menu in the balance.

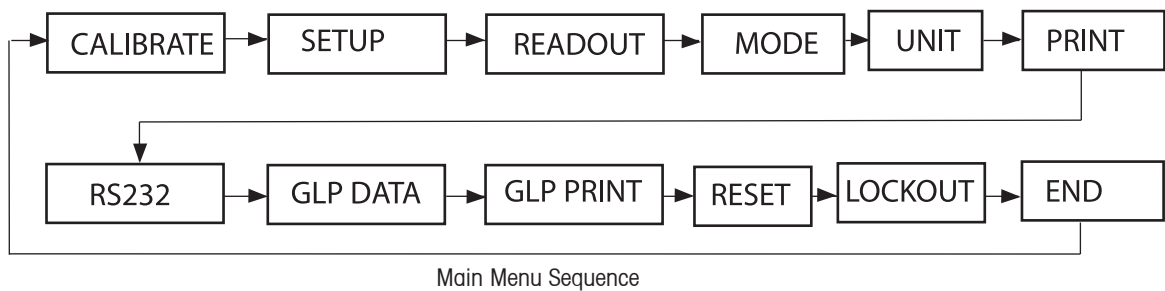

A long press of the **Menu** button will access the Main Menu.
Press the **Yes** button to enter the menu.
Press the **No** button to advance to the next menu selection.
Press **Exit** to return to the application mode.



3.7.2 Calibration

Discovery balances offer a choice of 4 calibration methods: Internal Calibration (Advanced AutoCal), Span Calibration, Calibration Test and Calibration Adjust.

- **Advanced AutoCal** - Two internal masses are used for linearization of calibration by using three weight values: zero, a weight value at midpoint of the balance’s weighing range, and a weight value at or near the balance’s specified capacity.

- **Span** - Span calibration ensures that the balance reads correctly within specifications using two weight values: zero and a weight value between 25% and 100% of the balance’s capacity.

- **Cal Test** - Calibration test allows the stored calibration data to be tested against the current mass being used for the test.

- **Cal Adj** - AutoCal allows adjustment of the internal calibration.

Notes: Calibration may be locked out to prevent unauthorized personnel from changing calibration. If calibration has been locked out, you can access Cal Test and AutoCal.

Before beginning calibration, have masses available. Masses required for calibration are listed in the table in this section.

To navigate the calibration menu, proceed as follows:

Press the **Yes** button to select the sub-menu selection.

Press **No** to advance to the next sub-menu selection.

press **Back** to go to previous sub-menu selection.

Press **Exit** to return to applicable mode.

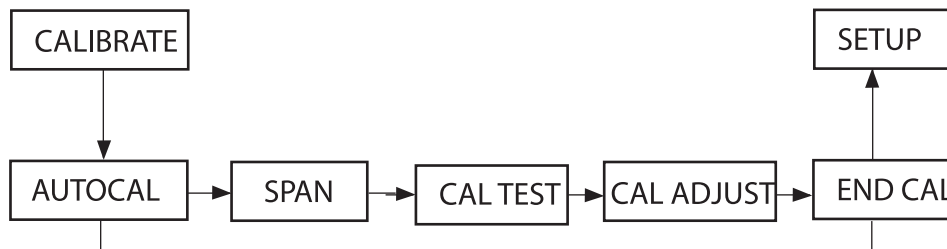

3.7.2 Calibration (Cont.)

Automatic Internal Calibration

Before Automatic Internal calibration can be used, it must be turned on first in Menu Calibrate. With the balance on, press and hold the **Cal** button until MENU CALIBRATE is displayed, then release the **Cal** button, CALIBRATE is (blinking).



Press the **Yes** button to enter calibration, CAL AUTO CAL is displayed.



Press the **Yes** button to select Autocal. After pressing the **Yes** button, AUTOCAL SET OFF is displayed.



Pressing the **No** button will change the display to AUTOCAL SET ON, then press the **Yes** button. With Autocal set on, exit the Calibrate Menu. The balance may now be calibrated automatically from the weighing mode.



Internal calibration can be accomplished without using an external weight. With the balance on, press the **Cal** button, balance begins to calibrate.

Press **Exit** to abort calibration. When internal calibration is finished, the balance returns to the currently selected mode.

Automatic internal calibration is a feature included with all Discovery models. AutoCal will automatically calibrate the balance each time a change in temperature significant enough to affect accuracy, or after every 11 hours.

Span Calibration

With the balance on, press and hold the **Cal** button, CALIBRATE (blinking) is displayed.



Press the **Yes** button to enter calibration.

Press the **No** button at AutoCal.

Press the **Yes** button to initiate span calibration.

First the zero reading is taken. Next the display shows the default span calibration weight value.



Press **No** to change to an alternate calibration weight. Press **Yes** when the desired calibration weight is displayed.

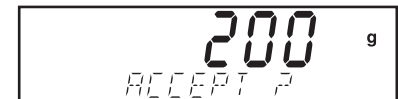

Place the specified calibration weight on the pan. After calibration, remove the weight from the pan.



To abort calibration at any time, press the **Exit** button.



3.7.2 Calibration (Cont.)

Calibration Test

Calibration test allows a check of a known calibration mass against the last stored calibration information in the balance.

Press and hold the **Cal** button until MENU CALIBRATE is displayed.

A rectangular display box containing the text "MENU" in large, bold, black digits on the top line, and "CALIBRATE" in smaller, black, spaced-out letters on the bottom line.

Press **Yes** to enter calibration.

Press **No** until CAL TEST is displayed.

A rectangular display box containing the text "CAL" in large, bold, black digits on the top line, and "CAL TEST" in smaller, black, spaced-out letters on the bottom line.

Press **Yes** and follow the screen instructions.

Place the specified weight on the pan. After a short period, the display indicates the difference in weight from the last calibration, and then will display the calibration weight on the pan. After the test, remove the calibration weight from the pan. To leave the menu, press **Exit**.

A rectangular display box containing the text "0.02" in large, bold, black digits on the top line, followed by a small "g" to the right. Below this, the word "DIFFERENCE" is displayed in smaller, black, spaced-out letters.

3.7.2 Calibration (Cont.)
Calibration Adjust

Calibration Adjust may be used to adjust the result of the internal calibration by ± 100 divisions.

Note: Before making a calibration adjustment, perform an internal calibration. To verify whether an adjustment is needed, place a test mass on the pan and note the difference (in divisions) between the nominal mass value and the actual reading. Refer to Calibration Masses Table and use the highest value from the Span Calibration Points column as the test mass. If the difference is within ± 1 division, calibration adjustment is not required. If the difference exceeds ± 1 division, calibration adjustment is recommended. Following a calibration adjustment, repeat the internal calibration and verification procedures.

To perform a calibration adjustment, press the **Cal** button and release it when MENU CALIBRATE is displayed.



Press **Yes** to enter the Calibration sub-menu. Press **No** until CAL ADJ is displayed.



Press **Yes** to enter the CAL ADJ menu item and view the current setting. If the actual reading was less than the nominal mass value, a positive adjustment is required.



Press **No** until the setting matches the difference noted earlier in the procedure. If the actual reading was greater than the nominal mass value, a negative adjustment is required.



Press **Back** until the setting matches the difference noted earlier in the procedure. Press **Yes** to accept and store the setting.



CALIBRATION MASSES TABLE

Model	Span Calibration Points (1)	Weight Class	
DV114C	100g	ASTMI Class I	OIML E1
DV214C	200g	ASTMI Class I	OIML E1
DV314C	300g	ASTMI Class I	OIML E1
DV215CD	200g	ASTMI Class I	OIML E1

3.7.3 Setup

SETUP	
Legal Trade	On/ Off
Auto Tare	On/ Off
Auto Off	Off , 1, 2, 5 min
Back Light	On/Off
End Setup	

Legal Trade

When set On, the balance operates in compliance with Weights and Measures regulations.

When the LEGAL TRADE menu item setting is set to ON, the following conditions apply:

- The CALIBRATION menu is hidden.
- The LEGAL TRADE menu item is hidden.
- The AUTO ZERO menu item setting is set to 0.5d and locked.
- The OUTPUT WHEN STABLE menu item setting is set to ON and locked.
- The CONTINUOUS setting in the AUTO PRINT menu item is hidden.

Auto Tare

When set On, the balance will automatically tare the first item placed on the pan.

Auto Off

When set to 1, 2 or 5 minutes, the balance will turn off in the selected time interval if there has been no activity. Set to OFF for continuous operation.

Backlight

When set On, display is illuminated at all times with balance on.

End Setup

Press the **Yes** button, to advance to the Readout submenu. Press the **No** button to return to the LEGAL TRADE menu item.

3.7.4 Readout

READOUT	
Auto Zero Off, .5d, 1d, 2d, 5d	
Filter	Low, Medium , High
Gross Ind.	G, B, Off
End Read	

Auto Zero

Allows setting the balance auto zero level setting: Off, .5, 1, 2 or 5 divisions. Balance maintains zero until threshold is exceeded.

Filter

Allows setting the balance filter level: Low, Medium, High. Compensates for vibration or excessive air currents.

Gross Ind.

Allows setting the gross indicator to G (gross), B (brutto) or Off.

End Read

Press the **Yes** button to advance to the Mode sub-menu. Press **No** to return to Auto Zero.

3.7.5 Mode

The Mode sub-menu is used to turn Application modes On or Off.

MODE	
Weigh	On/Off
Count	On/Off
	├ Apw Optimize On/Off
	└ End Count
Percent	On/Off
Check Weigh	On/Off
Animal	On/Off
	├ Filter
	├ Low, medium, High
	└ End Animal
GNT	On/Off
Totalize	On/Off
High Point	On/Off
Density	On/Off
	├ D Mode
	├ └ Liquid, Solid
	├ Aux Liquid
	├ └ Water, Other
	├ Porous
	├ └ On/Off
	└ End Density
Statistics	On/Off
	├ S Mode
	├ └ Weigh, Check,
	├ Animal
	├ └ Low, Medium, High
Pipette	On/Off
	├ Set Liquid
	├ └ Water, Other
	├ Set B Unit
	├ └ Atm, Inhg, Hpa,
	├ └ Mbar, Mmhg, Psia
	├ Set N Unit
	├ └ ML, UL
	└ End Pipette
End Mode	

Weigh

Use to set the Weighing Mode On or Off.

Count

Use to set the Counting Mode On or Off. If Count is set On, APW optimize can be set On or Off.

Percent

Allows setting the percent weighing mode On or Off.

Check Weigh

Use to set the Check Weighing Mode On or Off.

Animal

Use to set the Animal Weighing Mode to: Auto, Semi, Manual or Off. If set to Auto, Semi or Manual, level (averaging period) can be set to 5, 10 or 15 seconds.

G/N/T

Use to set the GNT mode On or Off.

Totalize

Use to set Totalize mode to: Manual, Auto or Off.

High Point

Use to set High Point On or Off.

Density Mode

Use to set Density Mode to Liquid or Solid, adjust liquid parameters and select Porous Mode on or off.

Statistics

Use to set Statistics Weigh, Check Weighing or Animal weighing On or Off.

Pipette

Use to set Pipette Test Liquid Water or Other, Barometer Atm, Inhg, Hpa, Mbar, MmHg or Psig and Nominal Units either ML or UL.

End Mode

Press the **Yes** button to advance to the Unit sub-menu. Press **No** to return to Weigh.

3.7.6 Unit

The Unit sub-menu is used to turn measuring units On or Off.

UNIT	
mg	On/Off
g	On/Off
ct	On/Off
oz	On/Off
ozt	On/Off
GN	On/Off
dwt	On/Off
m	On/Off
† HK	On/Off
† SG	On/Off
† TW	On/Off
Custom	On/Off
End Unit	

Defining Custom Unit

Set Custom to ON in the Unit menu to enable and define the Custom Unit. The custom unit is defined by a conversion factor and a least Significant Digit (LSD). The conversion factor is used by the balance to convert grams to the custom weighing unit and is defined by entering a factor and an exponent. The factor is a value between 0.1000000 and 1.999999 inclusive. The exponent moves the decimal point of the factor to the right for positive values or to the left for negative values.

Enter the Factor. Enter the Exponent and LSD using the **Yes** and **No** buttons.

Factor	Exponent (+3 to -3)	Conversion Factor
.1234	3	123.4
.1234	2	12.34
.1234	1	1.234
.1234	0	.1234
.1234	-1	.01234
.1234	-2	.001234
.1234	-3	.0001234

Custom Unit = Conversion Factor x Grams.

The LSD is the value by which the displayed weight is incremented or decremented.

LSD	Result
.5	Adds one decimal place
1	Display counts by 5
2	Display counts by 1
5	Display counts by 2
10	Display counts by 5
100	Display counts by 10
	Display counts by 100

End Unit

Press the **Yes** button to advance to the Print sub-menu. Press **No** to return to the first available unit.

3.7.7 Print

The Print sub-menu is used to set printing parameters for an external printer or computer.

PRINT-1		
Output	When Stable	On/Off
	GLP Tare	On/Off
Auto Print	Off, Cont., Interval, When Stable	
	1 -3600 seconds	
	Stable- Load, Load & Zero	
Content	Num Only-Off, all others	
	On-Header, Gross, Net, Tare, Ref, Result, GLP	
Layout	Line Format -Multi, Single	
	4LF-Yes/No	
	Form Feed-Yes/No	
List	Yes/No	
End Print-1		

Output

Set When Stable to On to print only stable values. Set When Stable to Off to print stable or unstable values.

Set GLP Tare to On to print GLP data once after a tare operation. Set GLP Tare to Off to disable this feature.

Auto Print

When set to Continuous, the displayed value is printed continuously. When set to Interval, the displayed value is printed at the user specified time interval (1 to 3600 seconds).

If set to When Stable, the balance will automatically print the displayed value when stability is achieved. An additional setting must be made to determine if only stable non-zero values will be printed (load setting) or if stable zero and non-zero values will be printed (Load & Zero). When set to Off, the Auto print feature is disabled.

Content

All of these features can be set On or Off. Numeric data only, Header, Gross, Net, Tare, Reference, Result, GLP. (See sample printout 3.10).

Layout

Determines the format of data output to a printer or computer. If Line Format is set to Multi, a multi-line printout is generated. If it is set to Single, a single line printout is generated. If 4 LF is set to yes, 4 line feeds are appended to the printout. If Form feed is set to Yes, a form feed is appended to the printout. This is useful for printing to page printers.

List

When Yes is selected, a printout of balance settings is generated.

End Print

Press the **Yes** button to advance to the next menu. Pressing **No** returns to Output menu item.

3.7.8 RS232

The RS232 sub-menu is used to set communication parameters for an external printer or computer.

RS232	
Baud	600..2400...19200
Parity	7 Even, 7 Odd, 7 No Par, 8 No Parity
Handshake	Off, XONXOFF, Hardware
End	

3.7.9 GLP Data

GLP DATA	
User ID	Set...
Proj ID	Set...
Time	Type-12hr, 24hr,
Date	Type mdy,...dym
	Set...
End GLP Data	

User ID

Used to enter a User ID up to 10 characters.

Project ID

Used to enter a Project ID up to 10 characters.

Entering a User ID or Project ID

Enter the user or Project ID one character at a time. The character to be entered is highlighted by a blinking cursor (underscore). Press the **No** button repeatedly to scroll through the list of available characters: (space), -, 0 through 9, A through Z. Press the **Yes** button to select the displayed character and move the cursor one position to the right. After the tenth character is entered, the ten character ID will blink. Press the **No** button to change the displayed ID or the **Yes** button to accept the ID and proceed to the next menu item.

Time

Type

Set the type to 12 hours or 24 hours.

Set

Set the current time using the format selected in the type menu item.

Date

Set the date type: M/D/Y, D/M/Y, Y/M/D, M/Y/D, Y/D/M, D/Y/M and the actual date.

End GLP Data

Press the **Yes** button to advance to the GLP Print sub-menu. Press the **No** button to return to User ID.

3.7.10 GLP Print

Select GLP items to be printed by setting them to On.

GLP PRINT	
Time	On/Off
Balance ID	On/Off
User ID	On/Off
Project ID	On/Off
Difference	On/Off
Name	On/Off
End GLP Prt	

End GLP Print

Press the **Yes** button to advance to the reset sub-menu. Press the **No** button to return to Time.

3.7.11 Reset

RESET	
Setup	RESET?
Readout	RESET?
Mode	RESET?
Unit	RESET?
Print	RESET?
RS232	RESET?
GLP Data	RESET?
GLP Print	RESET?
Lockout	RESET?
Global	RESET?
End Reset	

Setup

Select **Yes** to return all Setup menu items to their factory settings.

Readout

Select **Yes** to return all Readout menu items to their factory settings.

Mode

Select **Yes** to return all Mode menu items to their factory settings.

Unit

Select **Yes** to return all Unit menu items to their factory settings.

Print

Select **Yes** to return all Print menu items to their factory settings.

RS232

Select **Yes** to return all RS232 menu items to their factory settings.

GLP Data

Select **Yes** to return all GLP Data menu items to their factory settings.

GLP Print

Select **Yes** to return all GLP Print menu items to their factory settings.

Lockout

Select **Yes** to return all Lockout menu items to their factory settings.

Global

Select **Yes** to return the menu items in all sub-menus to their factory settings.

End Reset

Press the **Yes** button to advance to the Lockout menu. Press the **No** button to return to Setup.

3.7.12 Lockout

Use this sub-menu to prevent unauthorized changes to menu settings. If a sub-menu is locked, its menu item settings can be viewed but not changed.

LOCKOUT	
Cal	On/ Off
Setup	On/ Off
Readout	On/ Off
Mode	On/ Off
Unit	On/ Off
Print	On/ Off
RS232	On/ Off
GLP Data	On/ Off
GLP Print	On/ Off
Reset	On/ Off
Lockset	On/ Off
End Lockout	

Reset

Set On to lock the Reset Menu.

Lockset

Set On to lock the menu settings in Lockout.

End Lockout

Press the **Yes** button to advance to the End menu. Press the **No** button to return to the Cal menu.

3.7.13 End

The End menu is used to exit the menus and return to previous application

Cal

Set On to lock and hide the Calibration Menu.

0

Setup

Set On to lock the Setup Menu.

Readout

Set On to lock the Readout Menu.

Mode

Set On to lock the Mode Menu.

Unit

Set On to lock the Unit Menu.

Print

Set On to lock the Print Menu.

RS232

Set On to lock the RS232 Menu.

GLP Data

Set On to lock the GLP Data Menu.

GLP Print

Set On to lock the GLP Print Menu.

3.8 Sealing Access to the Balance Settings

When used in conjunction with the Lockout menu, the balance may be sealed to prevent or detect unauthorized changes to the balance settings. For legal for trade applications, the balance must be sealed to prevent access to the metrological parameters.

To seal the balance, cover the Lock switch access hole at the rear of the balance. A paper seal may be installed as shown.

NOTE: Consult local Weights and measures official to determine sealing method requirements.

To regain access to the locked balance settings, break the seal and power up the balance. When OHAUS appears on the display, press and hold the recessed Lock Switch until a weight is displayed.

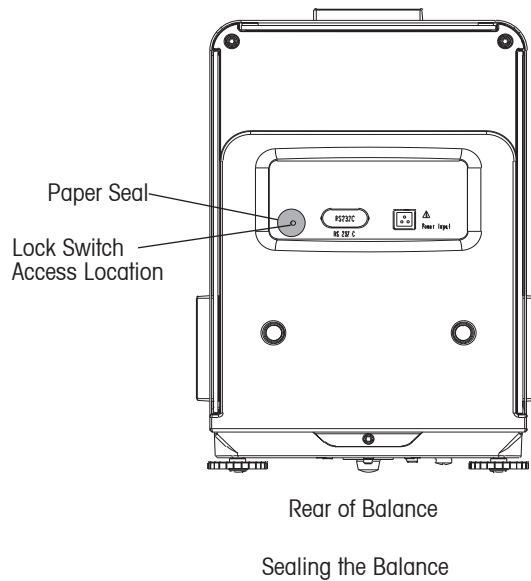

3.9 Printing Data

Printing data to an external computer or printer requires that the communication parameters in the RS232 sub-menu be set to match external device communication parameters.

```

04/01/06 12:30 PM
Bal ID 1234567
USER ID ABCDEFGHIJ
PROJ ID 1234567890
Name.....
0.0200kg G
0.0200kg T
0.0000kg NET
0.0200kg G

```

```

// if GLP SET> Time is ON
// If GLP SET> Balance ID is ON
// If GLP SET> User ID is ON
// If GLP SET> Proj ID is ON
// If GLP SET > Name is ON
// If a tare value is entered, these three items are printed if selected in the definition string.
// Gross ON - G, B or [space] as determined in Readout sub-menu.
// Tare ON
// Net ON
// Otherwise, gross is printed if selected in the definition string.
// Gross ON - G, B or [space] as determined in Readout sub-menu.

```

4. MAINTENANCE

4.1 Calibration

Periodically verify calibration by placing an accurate weight on the balance and if calibration is required, refer to section 3.7.2.

4.2 Cleaning

If cleaning is required, use a soft cloth dampened with water and a mild detergent. Do not allow liquids to enter the balance. Do not use harsh chemicals to clean the balance, as the finish may be damaged.

4.3 Troubleshooting

The following table lists common problems, possible causes and remedies. If the problem persists, contact Ohaus or your authorized Ohaus dealer.

TROUBLESHOOTING TABLE

Symptom	Possible Cause	Remedy
Balance will not turn on	<ul style="list-style-type: none"> AC power not connected AC power adapter defective 	<ul style="list-style-type: none"> Connect AC adapter Replace AC power adapter
Balance does not display accurately	<ul style="list-style-type: none"> Improper calibration Unstable environment 	<ul style="list-style-type: none"> Perform calibration Move balance to a suitable location
Cannot calibrate the balance	<ul style="list-style-type: none"> Calibration menu locked LFT set to on Unstable weight reading 	<ul style="list-style-type: none"> Turn Calibration menu lock off Turn LFT off Eliminate vibration and drafts.
Cannot change Menu settings	<ul style="list-style-type: none"> Submenu locked LFT set to on 	<ul style="list-style-type: none"> Unlock sub-menu Turn LFT off
Error 7.0	<ul style="list-style-type: none"> Unstable weight reading when defining the reference weight. 	<ul style="list-style-type: none"> Eliminate vibration and drafts.
Error 8.1	<ul style="list-style-type: none"> Weight reading exceeds Power On Zero limit. 	<ul style="list-style-type: none"> Clear pan.
Error 8.2	<ul style="list-style-type: none"> Weight reading below Power On Zero limit. 	<ul style="list-style-type: none"> Put pan on balance.
Error 8.3	<ul style="list-style-type: none"> Weight reading exceeds overload limit. 	<ul style="list-style-type: none"> Clear pan.
Error 8.4	<ul style="list-style-type: none"> Weight reading below underload limit. 	<ul style="list-style-type: none"> Put pan on balance.
Error 9.0	<ul style="list-style-type: none"> Internal fault. 	<ul style="list-style-type: none"> Return balance for service.
Error 9.5	<ul style="list-style-type: none"> Production calibration not present. 	<ul style="list-style-type: none"> Return balance for service.
Error 9.8	<ul style="list-style-type: none"> User calibration data not present. (Required for LFT ON only) 	<ul style="list-style-type: none"> Calibrate balance.
Error 53	<ul style="list-style-type: none"> EEPROM checksum error. 	<ul style="list-style-type: none"> Cycle power on, off. If balance fails to operate, return for service.
LOW REF WT	<ul style="list-style-type: none"> Average piece weight too small. (Warning) 	<ul style="list-style-type: none"> See section 3.5.3.
REF WT Err	<ul style="list-style-type: none"> Reference weight too small. The weight on the pan is too small to define a valid reference weight. 	<ul style="list-style-type: none"> Increase sample size.
-----	<ul style="list-style-type: none"> Busy (tare, zero, printing) 	<ul style="list-style-type: none"> Wait until completion.

4.4 Service Information

If the Troubleshooting section does not resolve or describe your problem, contact your authorized Ohaus Service Agent. For Service assistance or technical support in the United States, call toll-free 1-800-672-7722 between 8:00 AM and 5:00 PM EST. An Ohaus product service specialist will be available to provide assistance. Outside the USA, please visit our web site, www.ohaus.com to locate the office nearest you.

4.5 Parts

Description	Global Part Number
<ul style="list-style-type: none"> Power Pack, 100-240 Vac (Cord set required for US, UK, European, JP and Australian) 	30006112
<ul style="list-style-type: none"> Cord Set, 120 Vac, US Plug 	00088668
<ul style="list-style-type: none"> Cord Set, 230 Vac, UK Plug 	00089405
<ul style="list-style-type: none"> Cord Set, 230 Vac, European Plug 	00087925
<ul style="list-style-type: none"> Cord Set, 230 Vac, Australian Plug 	00088751
<ul style="list-style-type: none"> Cord Set, 100 Vac, JP Plug 	11107881
<ul style="list-style-type: none"> In-Use Cover Kit 	12103498
<ul style="list-style-type: none"> Replacement Pan DV114C, DV214C, DV215CD 	00223028
<ul style="list-style-type: none"> Replacement Pan DV314C 	00223023

4.6 Accessories

Storage Cover	80850012
Density Determination Kit	80850008
RS232 Cables	
<ul style="list-style-type: none"> Cable, DB9M-DB9F 	80500525
<ul style="list-style-type: none"> Cable, DB9M-DB25F 	80500524
<ul style="list-style-type: none"> Cable, DB9M-SF42 Printer 	80500571
<ul style="list-style-type: none"> Cable, DB9M-Apple 	80500562
Printer	30020467
Calibration Masses	
<ul style="list-style-type: none"> 100g ASTM Class1 	80780020
<ul style="list-style-type: none"> 200g ASTM Class 1 	80780023
<ul style="list-style-type: none"> 100g OIML E2 	80780275
<ul style="list-style-type: none"> 200g OIML E2 	80780276

5. TECHNICAL DATA

Ambient conditions

The technical data are valid under the following ambient conditions:

- Ambient temperature: 10 °C to 40 °C
- Relative humidity: Max. 80 % at 31 °C linearly decreasing to 50% at 40 °C, non-condensing
- Height above sea level: Up to 4000 m
- Warm-up time: At least 120 minutes after connecting balance to the power supply
- Storage temperature range: -10 °C to +70 °C
- Voltage fluctuations: -15% + 10%

Power

- AC adapter - To national standard as per list in Section 4.5. Balance power input 12 VAC, 50/60Hz 1.0A

Materials

- Base Housing: Painted Aluminum
- Draft Shield: Painted Aluminum
- Rear Cover: Plastic (Polyurethane)
- Terminal: ABS / PC Blend Plastic
- Weighing Pan: Stainless Steel
- In-Use Display Cover: PET Plastic
- Draftshield Doors: Glass

Protection

- Protected against dust and water
- Pollution degree: 2
- Installation category: Class II
- EMC: see declaration of conformity

5.1 Drawings

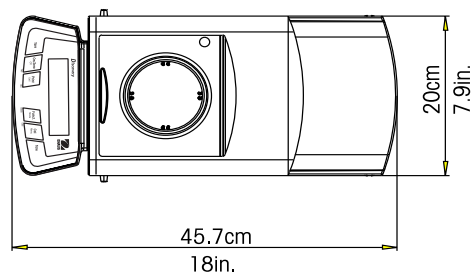
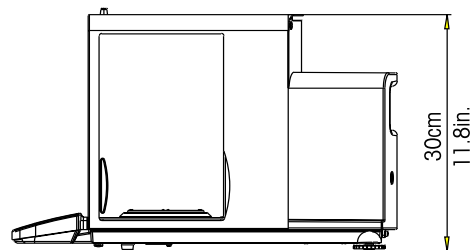

5.2 Specifications

Model	DV114C	DV214C	DV314C	DV215CD
Capacity	110	210	310	81/210
Readability (mg)	0.1			0.01/0.1
Repeatability (Std. dev) (mg)	0.1		0.2	0.02/0.1
Linearity (mg)	±0.2		±0.5	±0.08/0.2
Weighing Units	mg, g, oz, ct, dwt, ozt, GN, taels (3), mommes, Custom unit			
Application Modes	Weighing, Parts Counting, percent Weighing, Checkweighing, Animal/Dynamic Weighing, G/N/T, Totalization, High Point, Density, Statistics, Pipette			
Features	RS232 Interface, GLP Protocol, Integral Weigh-Below Hook, selectable Environmental Settings, Leveling indicator			
Tare Range	To Capacity by Subtraction			
Stabilization Time (s)	4		8	12/5
Sensitivity Drift (10-30°C)	±2ppm/°C			
Operating Temperature Range	10° to 40°C / 50° to 104° F			
Calibration	Automatic internal and manual external			
Power Requirements	External Adapter, 100-120VAC 1A, 220-240VAC 1A, 50/60Hz Plug configuration for US, Euro, UK, Japan and Australian			
Display Type	2-line Alphanumeric backlit LCD Display with Text Prompts			
Display Size (in/cm)	4 x 1 / 10 x 2.5			
Pan Size (Diameter) (in/cm)	3.5/9			
Free Height above pan (in/cm)	9.5/24			
Dimension WxHxD (in/cm)	7.9 x 11.8 x 18 / 20 x 30 x 45.7			
Net Weight (lb/kg)	29.5 / 13.4			
Shipping Dimension (in/cm)	15 x 18.9 x 25.6 / 38 x 48 x 65			

5.3 Capacity x Readability

Unit	DV114C	DV214C	DV314C	DV215CD
milligram	110000.0000 x 0.1	210000.0000 x 0.1	310000.0000 x 0.1	81000.000 x 0.01
gram	110 x 0.0001	210 x 0.0001	310 x 0.0001	81.000000 x 0.00001
ounce	3.8801356 x 0.000005	7.4075316 x 0.000005	10.9349276 x 0.000005	2.857191 x 0.0000005
carat	550.000000 x 0.0005	1050 x 0.0005	1550 x 0.0005	405.000000 x 0.00005
pennyweight	70.731639 x 0.0001	135.033129 x 0.0001	199.334619 x 0.0001	52.084207 x 0.00001
ounce troy	3.5365825 x 0.000005	6.7516575 x 0.000005	9.9667325 x 0.000005	2.604211 x 0.0000005
grain	1697.5596 x 0.002	3240.7956 x 0.002	4784.0316 x 0.002	1250.02116 x 0.0002
tael (Hong Kong)	2.9388975 x 0.000005	5.6106225 x 0.000005	8.2823475 x 0.000005	2.1640973 x 0.0000005
tael (Singapore)	2.9101017 x 0.000005	5.5556487 x 0.000005	8.2011957 x 0.000005	2.1428931 x 0.0000005
tael (Taiwan)	2.9333337 x 0.000005	5.6000007 x 0.000005	8.2666677 x 0.000005	2.160000 x 0.0000005
momme	29.333337 x 0.00005	56.000007 x 0.00005	82.666677 x 0.00005	21.600003 x 0.000005

5.4 Communication

The balance is equipped with an RS232 interface. Connecting the balance to a computer enables you to operate the balance from the computer, as well as receive data such as displayed weight.

5.4.1 Commands

Commands listed in the following table will be acknowledged by the balance. The balance will return "ES" for invalid commands.

Command	Function
IP	Immediate Print of displayed weight (stable or unstable).
P	Print displayed weight (stable or unstable).
CP	Continuous Print. OP ends Continuous Print.
SP	Print displayed stable weight.
SLP	Auto Print stable non-zero displayed weight.
SLZP	Auto Print stable non-zero weight and stable zero reading.
xP	Interval Print x = Print Interval (1-3600 seconds) OP ends Interval Print.
H	Enter Print Header Lines
Z	Same as pressing Zero Key
T	Same as pressing Tare Key.
xT	Establish a preset Tare value in grams. X= preset tare value in grams. To clear tare, enter 0 for x.
PT	Prints Tare weight stored in memory.
PM	Print current mode (weighing mode).
M	Scroll to the next enabled mode.
PU	Print current weighing unit.
U	Scroll to the next enabled unit.
OFF	Turns balance OFF.
ON	Turns balance on.
PSN	Print Serial Number.
PV	Print Version: name, software revision and LFT ON (if LFT is set ON).
x#	Set PC reference weight (x) in grams. (Must have an APW stored.)
P#	Print PC reference weight.

5.4.1 Commands (Cont.)

Command	Function
x%	Set % reference weight (x) in grams. (Must have reference weight stored.)
P%	Print percent reference weight.
xAW	Set Animal Weigh Level to x. (x = 1 (Low), 2 (Medium), 3 (High))
PAW	Print Animal Weigh Level.
BAW	Begin Animal cycle. (Manual Mode)
CW	Clear locked weight (weight < threshold) in Manual and Semi-Auto modes.
xCO	Set Checkweighing Over Limit in grams.
xCU	Set Checkweighing Under Limit in grams.
PCO	Print Checkweighing Over Limit.
PCU	Print Checkweighing Under Limit.
PTIME	Print current time.
PDATE	Print current date.
xAW	Set AW Mode, x=A (Automatic), x=S (Semi Automatic), x=M (Manual)

5.4.2 Connections

RS232 Interface

On the rear of the balance, the 9-pin female subminiature "D" connector is provided for interfacing to other devices. The pin connections are shown in the illustration below.

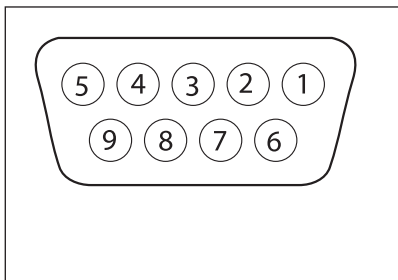

RS232 Connector

RS232 Pin Connections
1 – Remote Tare
2 – TxD
3 – RxD
4 – DSR
5 – Ground
6 – DTR
7 – CTS
8 – RTS
9 – Remote Print

* External PRINT and/or TARE switches may be installed as shown in the diagram. Momentary contact switches must be used. To enable this feature, contact Ohaus Aftermarket.

LIMITED WARRANTY

Ohaus products are warranted against defects in materials and workmanship from the date of delivery through the duration of the warranty period. During the warranty period Ohaus will repair, or, at its option, replace any component(s) that proves to be defective at no charge, provided that the product is returned, freight prepaid, to Ohaus.

This warranty does not apply if the product has been damaged by accident or misuse, exposed to radioactive or corrosive materials, has foreign material penetrating to the inside of the product, or as a result of service or modification by other than Ohaus. In lieu of a properly returned warranty registration card, the warranty period shall begin on the date of shipment to the authorized dealer. No other express or implied warranty is given by Ohaus Corporation. Ohaus Corporation shall not be liable for any consequential damages.

As warranty legislation differs from state to state and country to country, please contact Ohaus or your local Ohaus dealer for further details.



Ohaus Corporation
7 Campus Drive
Suite 310
Parsippany, NJ 07054, USA
Tel: (973) 377-9000
Fax: (973) 944-7177

With offices worldwide
www.ohaus.com



P/N 80104130 E © 2014 Ohaus Corporation, all rights reserved.

Printed in Switzerland