

MT1260 Single point load cell 50kg~635kg

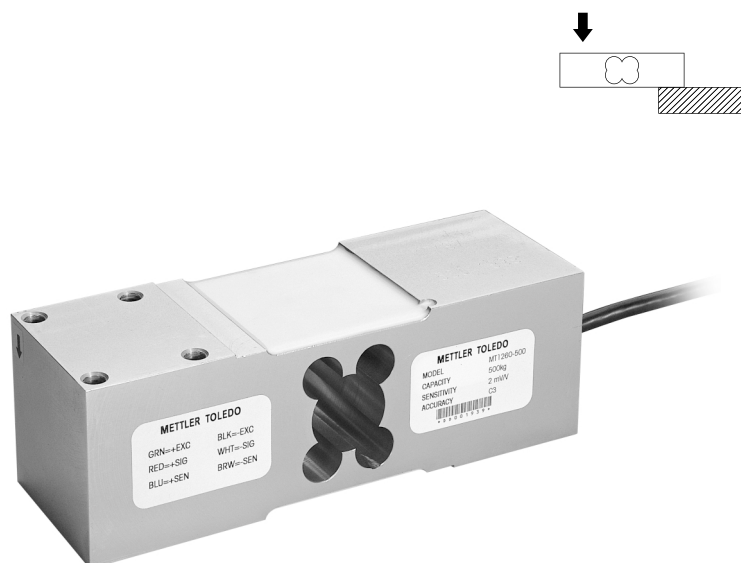

Features:

- Single point aluminum load cell
- OIML R60 C3 approved
- Protection class IP 67
- Off center load compensated (OIML R76)
- Ideal for platform scales, packing and process weighing equipment

Specification

Rated capacity	kg	50,75,100,150,200,250,300,500,635
Rated output	mV/V	2 ± 10%
Accuracy class		OIML R60 C3
Zero balance	%R.C.	≤ 10
Temp. Compensated range	°C	-10~+40
Operating temp. Range	°C	-20~+65
Input resistance	Ω	410 ± 10
Output resistance	Ω	350 ± 4
Insulation resistance	MΩ	≥ 5000(50V DC)
Recommended voltage	V(DC/AC)	5~15
Max. excit. voltage	V(DC/AC)	20
Safe overload	%R.C.	150
Ultimated overload	%R.C.	300
Protection class		IP67
Max. platform size	mm	600 x 600
Cable length	m	2

- 1) The combined maximum error due to nonlinearity, hysteresis and temperature effect on output, does not exceed the error limits to OIML-R60.
- 2) All relative errors specified refer to the output signal at nominal load.

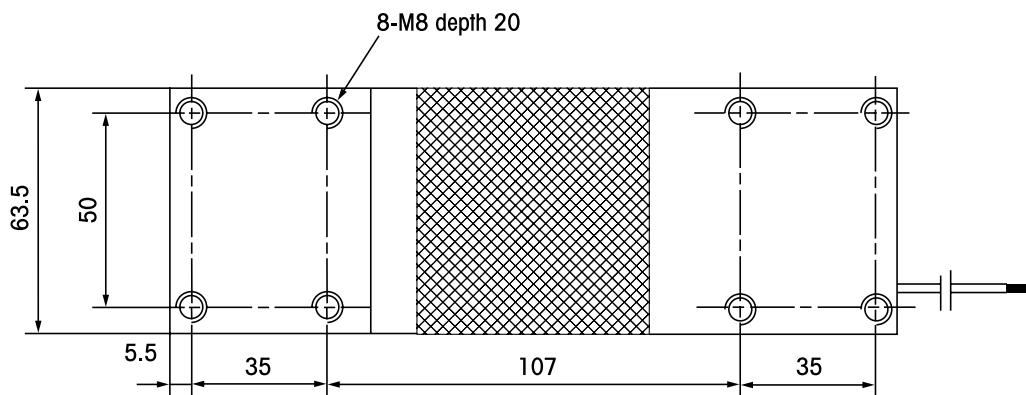
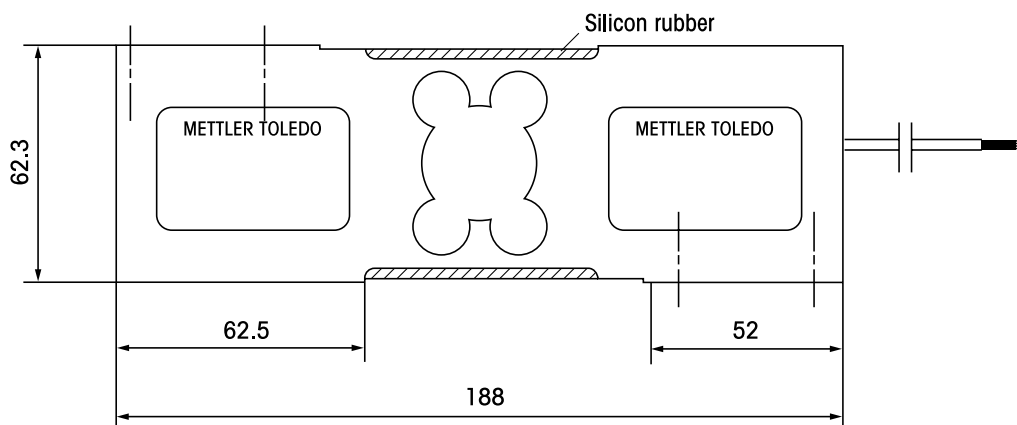

Cable Color	Code(six-wire circuit)
Green	+Excitation
Black	-Excitation
Red	+Signal
White	-Signal
Blue	+Sense
Brown	-Sense
Yellow(long)	Shield

Mounting:

Capacity (kg)	Tightening Torque (N·m)
≤300	25
≤300	30