



Moisture analyzer is a laboratory measuring instrument intended to determine relative humidity for small samples of different materials. MA.R series redefines moisture analyzers standards. This series has been equipped with brand new readable LCD display providing an extra text line for information such as supplementary messages and data, e.g. product name or tare value. The moisture analyzer, using respective pictograms, signalizes currently activated mode, computer connection and functions, both balance and service ones.

The MA.R series is enriched with various interfaces: RS232, USB type A, USB type B and Wifi as an option. The moisture analyzer is housed in a plastic casing.

## DATABASES

Information system of R series moisture analyzers is based on 6 databases, allowing many operators to operate product database comprising many samples. Collected measurements may be subjected to subsequent analysis.

Collected data is registered in 6 databases:

- Users (up to 100 users)
- Products (up to 1000 products)
- Weighments (up to 1000 weighments)
- Tares (up to 100 tares)
- Programs (up to 100 drying programs)
- Drying process reports (up to 1000 reports)

Exchange of information within the system is performed by means of USB port on bi-directional basis. It is possible to import and export databases using memory sticks.

## Direct access to information

It is possible to access functions and databases directly, using keyboard soft keys.

**Database** – access to databases

**Function** – access to basic functions

**F1 and F2** – programmable function keys and menu navigation keys

**Reports** – access to database of drying process reports

**Profile** – access to parameters settings

**Sample** – access to products database

## Technical specification:

	MA 50/1.R	MA 50.R	MA 110.R	MA 210.R
Max capacity	50 g	50 g	110 g	210 g
Reading unit	0,1 mg	1 mg	1 mg	1 mg
Tare range	-50 g	-50 g	-110 g	-210 g
Max sample weight	50 g	50 g	110 g	210 g
Moisture readout accuracy	0,0001 %	0,001 %	0,001 %	0,001 %
Moisture content repeatability	0,05% (sample weight of 2 g), 0,01% (sample weight of 10 g)			
Max sample height	h= 20 mm			
Weighing pan size	Ø 90 mm, h= 8 mm			
Drying temperature range	max. 160° C			
Heating module *	IR emitter			
Drying mode	4 drying modes (standard, quick, step, mild)			
Auto switch-off options	4 options (time-defined, automatic, manual, user-defined)			
Additional functions	sample identification			
Power supply	230V			
LCD display	LCD (backlit)			
Interface	1 × RS 232, USB-A, USB-B, WiFi (option)			
Net weight/gross weight	4,9 / 6,4 kg			
Packaging size	470×380×336 mm			

\* Heating element options: WH - halogen (max= 250° C), NS - metal heater (max=160° C)

## Dimensions:

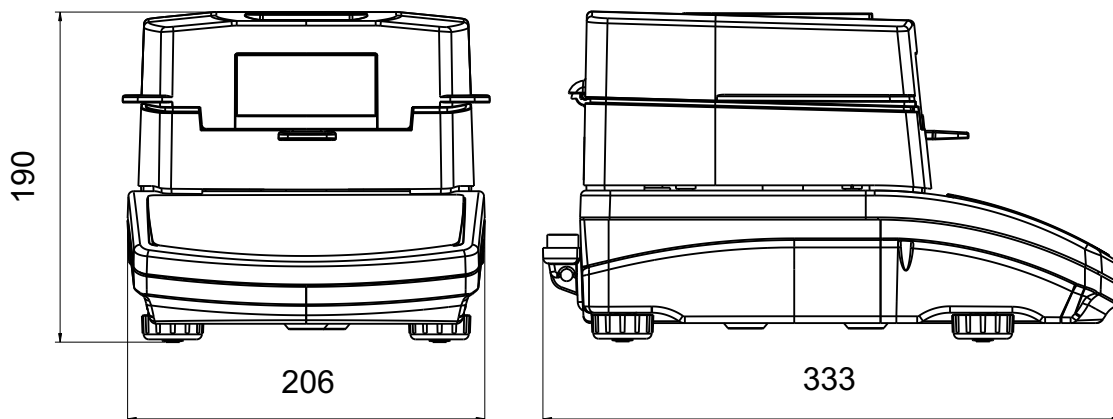

## Additional equipment:

Anti-Vibration Table (coated or stainless steel)	GT105k-12/Z Control Thermometer
EPSON Printer	Adjustment Weight
Disposable Weighing Pans	PW-WIN, RAD-KEY PC Software
PC Keyboard	Calbe RS 232 (balance - computer) "P0108"
Water Vapour Permeability Determination Set	Cable RS 232 (balance - Epson, Citizen printer) "P0151"